

UNITED STEEL PRODUCTS

USP

ROLLING COUNTER SHUTTERS MODEL 550



HIGHLIGHTS

- **Torsion spring counterbalance**
- **Galvanized steel hood**
- **Aluminum guides**
- **22 gauge galvanized steel curtain**
- **Galvanized steel stamped endlocks**
- **Steel angle bottom bar**
- **Easy servicing**

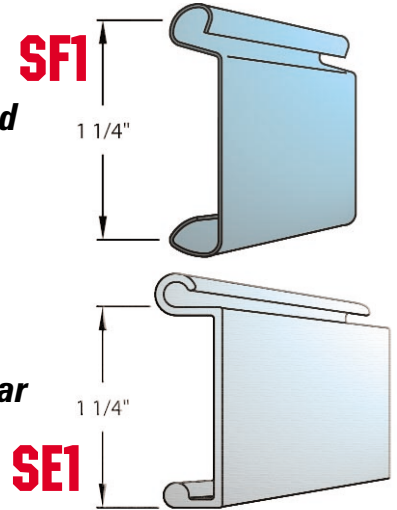

SPECIFICATIONS

Furnish Rolling Shutter, series 550 as manufactured by "USP" complete with curtain, hood, guides, counterbalance and options as specified.

OPERATION

- manual lift
- internal or external industrial motors
- hand crank using gear reduction and removable hand crank

CURTAIN MODEL 550 consists of interlocking slats cold rolled formed from hot dipped galvanized steel with optional baked on grey polyester enamel coating or 304 stainless steel with a #4 finish curved flat profile SF1 or extruded aluminum profile SE1. Each end of alternate slats are to be assembled with galvanized steel end locks to maintain slat alignment and to act as a wearing surface inside the door guides. Slat thickness shall be calculated with U.S. gauging with a minimum of 22 gauge. Steel slats are to be hot dipped galvanized as per A.S.T.M. A653. Each curtain shall receive a bottom bar to maintain slat alignment and posture.

BOTTOM BAR shall consist of one steel factory painted angle a minimum 1/8" thick. Bottom bar shall be provided with a lift handle and slide bolts.

SPRING COUNTERBALANCE is to be housed in a steel pipe of the appropriate diameter and wall thickness as to support curtain. Deflection shall be limited to a maximum of .03" per ft. of door width. Springs are to consist of helical torsion type designed to meet a 25% safety load factor. Safety factor allows for safe operation, ease of use, and longer spring life. Springs are to be grease packed and anchored, using a cast iron anchor, to a cold rolled steel inner shaft. Spring tension shall be fully adjustable from outside of end bracket plate. To insure smooth operation end bracket plates shall contain sealed ball bearings to minimize wear of pipe shaft.

END BRACKET plates shall consist of factory painted steel plates no less than 1/8" thick. Bracket plates are to house pipe shaft and counterbalance assembly. Shaft is attached to plate by sealed ball bearings fitted onto plate.

GUIDES shall consist of extruded aluminum channels a minimum of 2" deep. Guides will bolt together and feature a removable door stop. The guide depth shall be of a length adequate to provide for proper slat penetration.

HOODS shall consist of a minimum of #24 gauge hot dipped galvanized steel with a baked on grey or bronze polyester enamel coating. Hoods are designed to protect and house counterbalance assembly. To prevent hood sag intermediate supports shall be furnished as required.

LOCKING for manual and crank operated doors to be slidebolts mounted on bottom bar with provisions for padlocks. Gearing within motors to be self locking.

FINISH all non-galvanized surfaces shall receive a factory coat of rust inhibiting enamel. Aluminum standard is mil finish. Field painting not included in this section.

INSTALLATION to be by USP or by an authorized dealer.

OPTIONS

- Baked on grey polyester enamel slats • Stainless steel slats •
- **Poly-cote®** polyester powder coating, 200 select colors •
- Clear, bronze or black anodizing •
- Bend steel guides •
- Perforated slat section •
- Weatherseal package •
- Cylinder locks in bottom bar •
- Safety edge • Remote Control • Timer to close •
- Cylinder locks • Electric interlocks •
- Fire Shutter (see Model 750) •

CLEARANCE DETAILS 550 SERIES

MANUAL OPERATION

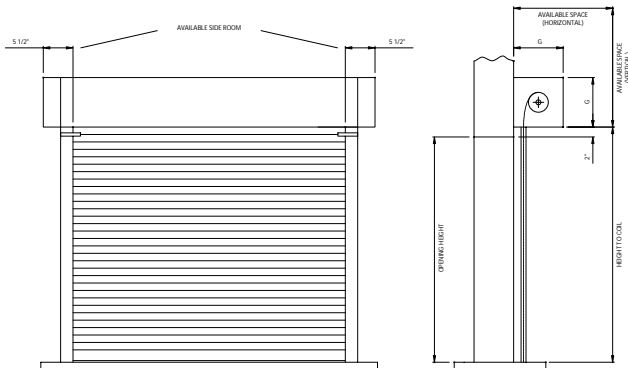

FACE OF WALL



TUBE

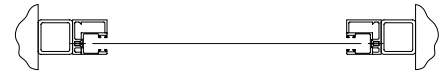

TUBE / BETWEEN THE JAMBS

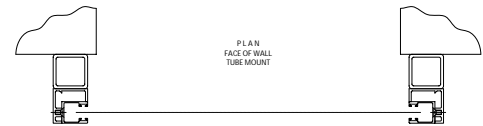

CRANK OPERATION

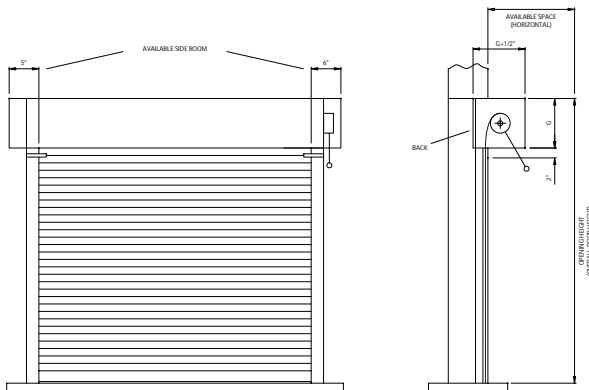

Self supporting structural steel tube members are supplied with USP shutters when specified. Tubes permit the installation of shutters independent of adjacent construction. The tubes are anchored to the floor slab, and to steel beams or joists above.

MOTOR OPERATION

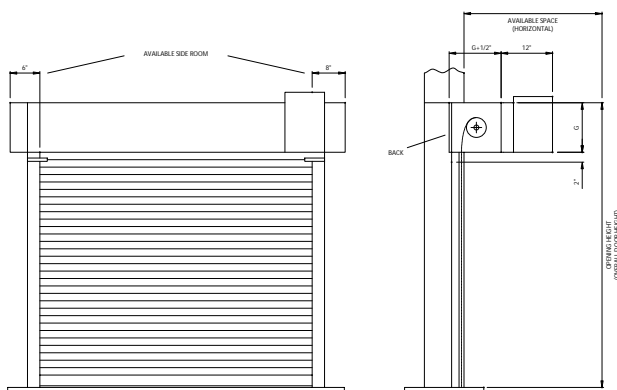

FACE OF WALL

Face of Wall

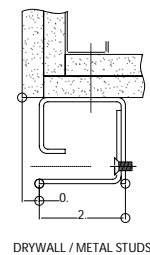
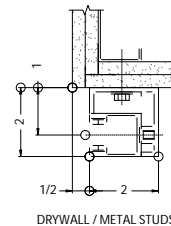

BETWEEN THE JAMBS

BETWEEN THE JAMBS

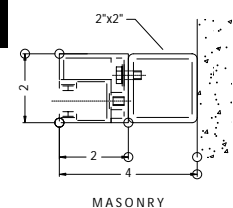
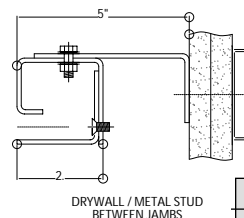

MATERIAL CHOICES

Mild Steel Grade A36
 Aluminum Type 6061
 Stainless Steel Type 304
 Stainless Steel Type 316

SHUTTER FINISHES

MA Mill finish aluminum
CA Clear Anodized
PS Primed Steel
SS Stainless Steel
PC Powder Coat

HEIGHT	C
to 3'0"	11"
3'0" to 5'6"	12"
5'6" to 8'0"	13"
8'0" to 10'1"	14"

Where clearances are critical, dimensions can be reduced. Refer inquiries to our Engineering Department.

UNITED STEEL PRODUCTS, INC.

33-40 127th Place Flushing, NY 11368

(718) 478-5330 Fax (718) 779-3202

<http://www.unitedsteelproducts.com>