

# Bar Size Angle



Common grade: ASTM A36.....min. 36,000 yield / min. 58,000 tensile

Size						Weight (lbs.)	Weight (lbs.)	
A		B		C		per Foot	per 20'	
1/2	x	1/2	x	1/8		0.38	7.6	
5/8	x	5/8	x	1/8		0.48	9.6	
3/4	x	3/4	x	1/8		0.59	11.8	
7/8	x	7/8	x	1/8		0.70	14.0	
1	x	1	x	1/8		0.80	16.0	
				3/16		1.16	23.2	
				1/4		1.49	29.8	
1	1/4	x	1	1/4	x	1/8	1.01	20.2
				3/16		1.48	29.6	
				1/4		1.92	38.4	
1	1/2	x	1	1/2	x	1/8	1.23	24.6
				3/16		1.80	36.0	
				1/4		2.34	46.8	
				3/8		3.35	67.0	
1	3/4	x	1	3/4	x	1/8	1.44	28.8
				3/16		2.12	42.4	
				1/4		2.77	55.4	
	2	x	1	1/4	x	3/16	1.96	39.2
				1/4	x	1/4	2.55	51.0
	2	x	1	1/2	x	1/8	1.44	28.8
				3/16		2.12	42.4	
				1/4		2.77	55.4	
	2	x	2	x	1/8	1.65	33.0	
				3/16		2.44	48.8	
				1/4		3.19	63.8	
				5/16		3.92	78.4	
				3/8		4.70	94.0	
2	1/2	x	1	1/2	x	3/16	2.44	48.8
				1/4		3.19	63.8	
				5/16		3.92	78.4	
2	1/2	x	2	x	3/16	2.75	55.0	
				1/4		3.62	72.4	
				5/16		4.50	90.0	
				3/8		5.30	106.0	
2	1/2	x	2	1/2	x	3/16	3.07	61.4
				1/4		4.10	82.0	
				5/16		5.00	100.0	
				3/8		5.90	118.0	
				1/2		7.70	154.0	

# Structural Angle



Common grades: ASTM A36.....min. 36,000 yield / min. 58,000 tensile  
 ASTM A572 Gr. 50.....min. 50,000 yield / min. 65,000 tensile

Size				Weight (lbs.)	Weight (lbs.)	Weight (lbs.)
A	B	C		per Foot	per 20'	per 40'
3	x 2	x	3/16	3.07	61.4	122.8
			1/4	4.10	82.0	164.0
			5/16	5.00	100.0	200.0
			3/8	5.90	118.0	236.0
			1/2	7.70	154.0	308.0
3	x 2 1/2	x	1/4	4.50	90.0	180.0
			5/16	5.60	112.0	224.0
			3/8	6.60	132.0	264.0
			1/2	8.50	170.0	340.0
3	x 3	x	3/16	3.71	74.2	148.4
			1/4	4.90	98.0	196.0
			5/16	6.10	122.0	244.0
			3/8	7.20	144.0	288.0
			1/2	9.40	188.0	376.0
3 1/2	x 2 1/2	x	1/4	4.90	98.0	196.0
			5/16	6.10	122.0	244.0
			3/8	7.20	144.0	288.0
			1/2	9.40	188.0	376.0
3 1/2	x 3	x	1/4	5.40	108.0	216.0
			5/16	6.60	132.0	264.0
			3/8	7.90	158.0	316.0
			1/2	10.20	204.0	408.0
3 1/2	x 3 1/2	x	1/4	5.80	116.0	232.0
			5/16	7.20	144.0	288.0
			3/8	8.50	170.0	340.0
			1/2	11.10	222.0	444.0
4	x 3	x	1/4	5.80	116.0	232.0
			5/16	7.20	144.0	288.0
			3/8	8.50	170.0	340.0
			1/2	11.10	222.0	444.0
4	x 3 1/2	x	1/4	6.20	124.0	248.0
			5/16	7.70	154.0	308.0
			3/8	9.10	182.0	364.0
			1/2	11.90	238.0	476.0
4	x 4	x	1/4	6.60	132.0	264.0
			5/16	8.20	164.0	328.0
			3/8	9.80	196.0	392.0
			1/2	12.80	256.0	512.0
			5/8	15.70	314.0	628.0
			3/4	18.50	370.0	740.0

5	x	3	x	1/4	6.60	132.0	264.0
				5/16	8.20	164.0	328.0
				3/8	9.80	196.0	392.0
				1/2	12.80	256.0	512.0
				5/8	16.80	336.0	672.0
5	x	3 1/2	x	1/4	7.00	140.0	280.0
				5/16	8.70	174.0	348.0
				3/8	10.40	208.0	416.0
				1/2	13.60	272.0	544.0
				5/8	16.80	336.0	672.0
5	x	5	x	5/16	10.30	206.0	412.0
				3/8	12.30	246.0	492.0
				1/2	16.20	324.0	648.0
				5/8	20.00	400.0	800.0
				3/4	23.60	472.0	944.0
6	x	3 1/2	x	1/4	7.90	158.0	316.0
				5/16	9.80	196.0	392.0
				3/8	11.70	234.0	468.0
				1/2	15.30	306.0	612.0
6	x	4	x	5/16	10.30	206.0	412.0
				3/8	12.30	246.0	492.0
				1/2	16.20	324.0	648.0
				5/8	20.00	400.0	800.0
				3/4	23.60	472.0	944.0
6	x	6	x	5/16	12.50	250.0	500.0
				3/8	14.90	298.0	596.0
				1/2	19.60	392.0	784.0
				5/8	24.20	484.0	968.0
				3/4	28.70	574.0	1148.0
				1	37.40	748.0	1496.0
7	x	4	x	3/8	13.60	272.0	544.0
				1/2	17.90	358.0	716.0
				5/8	22.10	442.0	884.0
				3/4	26.20	524.0	1048.0
8	x	4	x	1/2	19.60	392.0	784.0
				5/8	24.20	484.0	968.0
				3/4	28.70	574.0	1148.0
				1	37.40	748.0	1496.0
8	x	6	x	1/2	23.00	460.0	920.0
				5/8	28.50	570.0	1140.0
				3/4	33.80	676.0	1352.0
				1	44.20	884.0	1768.0
8	x	8	x	1/2	26.40	528.0	1056.0
				5/8	32.70	654.0	1308.0
				3/4	38.90	778.0	1556.0
				1	51.00	1020.0	2040.0
9	x	4	x	1/2	21.30	426.0	852.0

## Bar Size Channel



Common grade: ASTM A36.....min. 36,000 yield / min. 58,000 tensile

Depth	Web		Flange		Weight (lbs.) per Foot	Weight (lbs.) per 20'
	Thickness		Width			
3/4	x	3/8	x	1/8	0.56	11.2
1	x	3/8	x	1/8	0.68	13.6
1	x	1/2	x	1/8	0.84	16.8
1 1/8	x	9/16	x	3/16	1.16	23.2
1 1/4	x	1/2	x	1/8	1.01	20.2
1 1/2	x	1/2	x	1/8	1.12	22.4
1 1/2	x	9/16	x	3/16	1.44	28.8
1 1/2	x	3/4	x	1/8	1.17	23.4
2	x	1/2	x	1/8	1.43	28.6
2	x	9/16	x	3/16	1.86	37.2
2	x	5/8	x	1/4	2.28	45.6
2	x	1	x	1/8	1.59	31.8
2	x	1		3/16	2.32	46.4
2 1/2	x	5/8	x	3/16	2.27	45.4

## Standard Channel

Common grades: ASTM A36.....min. 36,000 yield / min. 58,000 tensile  
 ASTM A572 Gr. 50.....min. 50,000 yield / 65,000 tensile



Depth	Weight (lbs.)		Web	Flange	Weight (lbs.)	Weight (lbs.)
	per Foot	Thickness	Width	per 20'	per 40'	
C 3	x	4.100	0.170	1.410	82	164
		5.000	0.258	1.498	100	200
		6.000	0.356	1.596	120	240
C 4	x	5.400	0.184	1.584	108	216
		6.250	0.247	1.647	125	250
		7.250	0.321	1.721	145	290
C 5	x	6.700	0.190	1.750	134	268
		9.000	0.325	1.885	180	360
		8.200	0.200	1.920	164	328
C 6	x	10.500	0.314	2.034	210	420
		13.000	0.437	2.157	260	520
		9.800	0.210	2.090	196	392
C 7	x	12.250	0.314	2.194	245	490
		14.750	0.419	2.299	295	590
		11.500	0.220	2.260	230	460
C 8	x	13.750	0.303	2.343	275	550
		18.750	0.487	2.527	375	750
		13.400	0.233	2.433	268	536
C 9	x	15.000	0.285	2.485	300	600
		20.000	0.448	2.648	400	800
		15.300	0.240	2.600	306	612
C 10	x	20.000	0.379	2.739	400	800
		25.000	0.526	2.886	500	1000
		30.000	0.673	3.033	600	1200
C 12	x	20.700	0.282	2.942	414	828
		25.000	0.387	3.047	500	1000
		30.000	0.510	3.170	600	1200
C 15	x	33.900	0.400	3.400	678	1356
		40.000	0.520	3.520	800	1600
		50.000	0.716	3.716	1000	2000

## MC Channel



Common grades: **ASTM A36.....min. 36,000 yield / min. 58,000 tensile**  
**ASTM A572 Gr. 50.....min. 50,000 yield / min. 65,000 tensile**

			Weight (lbs.)	Web	Flange	Weight (lbs.)	Weight (lbs.)
	Depth		per Foot	Thickness	Width	per 20'	per 40'
MC	3	x	7.1	0.312	1.938	142	284
MC	4	x	13.8	0.500	2.500	276	552
MC	6	x	12.0	0.310	2.497	240	480
			15.1	0.316	2.941	302	604
			15.3	0.340	3.500	306	612
			16.3	0.375	3.000	326	652
			18.0	0.379	3.504	360	720
MC	7	x	19.1	0.352	3.452	382	764
			22.7	0.503	3.603	454	908
MC	8	x	18.7	0.353	2.978	374	748
			20.0	0.400	3.025	400	800
			21.4	0.375	3.450	428	856
			22.8	0.427	3.502	456	912
MC	9	x	23.9	0.400	3.450	478	956
			25.4	0.450	3.500	508	1016
MC	10	x	22.0	0.312	3.500	440	880
			25.0	0.380	3.405	500	1000
			28.5	0.425	3.950	570	1140
			33.6	0.575	4.100	672	1344
			41.1	0.796	4.321	822	1644
MC	12	x	31.0	0.370	3.670	620	1240
			35.0	0.467	3.767	700	1400
MC	12	x	40.0	0.590	3.890	800	1600
			45.0	0.712	4.012	900	1800
			50.0	0.835	4.135	1000	2000
MC	13	x	31.8	0.375	4.000	636	1272
			50.0	0.787	4.412	1000	2000
MC	18	x	42.7	0.450	3.950	854	1708
			45.8	0.500	4.000	916	1832
			51.9	0.600	4.100	1038	2076
			58.0	0.700	4.200	1160	2320

## JR Channel



Common grade: **ASTM A36.....min. 36,000 yield / min. 58,000 tensile**

			Weight (lbs.)	Web	Flange	Weight (lbs.)	Weight (lbs.)
	Depth		per Foot	Thickness	Width	per 20'	per 40'
JR	8	x	8.5	0.180	1.875	170	340
JR	10	x	6.5	0.152	1.127	130	260
			8.4	0.170	1.500	168	336
JR	12	x	10.6	0.190	1.500	212	424

## S Beam (I Beam)



Common grade: ASTM A992.....min. 50,000 yield / min. 65,000 tensile

Depth		x	Weight (lbs.)	Web	Flange	Flange	Weight (lbs.)	Weight (lbs.)
			per Foot	Thickness	Width	Thickness	per 20'	per 40'
S 3	x		5.7	0.170	2.330	0.260	114	228
			7.5	0.349	2.509	0.260	150	300
S 4	x		7.7	0.193	2.663	0.293	154	308
			9.5	0.326	2.796	0.293	190	380
S 5	x		10.0	0.214	3.004	0.326	200	400
			14.75	0.494	3.284	0.326	295	590
			12.5	0.232	3.332	0.359	250	500
S 6	x		17.25	0.465	3.565	0.359	345	690
			15.3	0.252	3.662	0.392	306	612
			20.0	0.450	3.860	0.392	400	800
S 8	x		18.4	0.271	4.001	0.425	368	736
			23.0	0.441	4.171	0.425	460	920
S 10	x		25.4	0.311	4.661	0.491	508	1016
			35.0	0.594	4.944	0.491	700	1400
S 12	x		31.8	0.350	5.000	0.544	636	1272
			35.0	0.428	5.078	0.544	700	1400
			40.8	0.472	5.252	0.659	816	1632
			50.0	0.687	5.477	0.659	1000	2000
			42.9	0.411	5.501	0.622	858	1716
S 15	x		50.0	0.550	5.564	0.622	1000	2000
			54.7	0.461	6.001	0.691	1094	2188
S 18	x		70.0	0.711	6.251	0.691	1400	2800
			66.0	0.505	6.255	0.795	1320	2640
S 20	x		86.0	0.660	7.060	0.920	1720	3440
			80.0	0.500	7.000	0.870	1600	3200
			100.0	0.745	7.245	0.870	2000	4000
S 24	x		106.0	0.620	7.870	1.090	2120	4240

## JR Beam



Common grade: ASTM A36.....min. 36,000 yield / min. 58,000 tensile

Depth		x	Weight (lbs.)	Web	Flange	Flange	Weight (lbs.)
			per Foot	Thickness	Width	Thickness	per 40'
JR 6	x		4.4	0.114	1.844	0.171	176
JR 8	x		6.5	0.135	2.281	0.189	260
JR 10	x		9.0	0.157	2.690	0.206	360
JR 12	x		11.8	0.177	3.065	0.225	472

## W Beam (Wide Flange)



Common grade: ASTM A992.....min. 50,000 yield / min. 65,000 tensile

	Nominal Depth		Weight (lbs.) per Foot	Actual Depth*	Web Thickness	Flange Width	Flange Thickness	Weight (lbs.) per 40'
W	4	x	13	4.16	0.280	4.060	0.345	520
W	5	x	16	5.01	0.240	5.000	0.360	640
W			19	5.15	0.270	5.030	0.430	760
W	6	x	9	5.90	0.170	3.940	0.215	360
			12	6.03	0.230	4.000	0.280	480
			15	5.99	0.230	5.990	0.260	600
			16	6.28	0.260	4.030	0.405	640
			20	6.20	0.260	6.020	0.365	800
			25	6.38	0.320	6.080	0.455	1000
W	8	x	10	7.89	0.170	3.940	0.205	400
			13	7.99	0.230	4.000	0.255	520
			15	8.11	0.245	4.015	0.315	600
			18	8.14	0.230	5.250	0.330	720
			21	8.28	0.250	5.270	0.400	840
			24	7.93	0.245	6.495	0.400	960
			28	8.06	0.285	6.535	0.465	1120
			31	8.00	0.285	7.995	0.435	1240
			35	8.12	0.310	8.020	0.495	1400
			40	8.25	0.360	8.070	0.560	1600
			48	8.50	0.400	8.110	0.685	1920
			58	8.75	0.510	8.220	0.810	2320
			67	9.00	0.570	8.280	0.935	2680
W	10	x	12	9.87	0.190	3.960	0.210	480
			15	9.99	0.230	4.000	0.270	600
			17	10.11	0.240	4.010	0.330	680
			19	10.24	0.250	4.020	0.395	760
			22	10.17	0.240	5.750	0.360	880
			26	10.33	0.260	5.770	0.440	1040
			30	10.47	0.300	5.810	0.510	1200
			33	9.73	0.290	7.960	0.435	1320
			39	9.92	0.315	7.985	0.530	1560
			45	10.10	0.350	8.020	0.620	1800
			49	9.98	0.340	10.000	0.560	1960
			54	10.09	0.370	10.030	0.615	2160
			60	10.22	0.420	10.080	0.680	2400
			68	10.40	0.470	10.130	0.770	2720
			77	10.60	0.530	10.190	0.870	3080
			88	10.84	0.605	10.265	0.990	3520
			100	11.10	0.680	10.340	1.120	4000
			112	11.36	0.755	10.415	1.250	4480
W	12	x	14	11.91	0.200	3.970	0.225	560
			16	11.99	0.220	3.990	0.265	640
			19	12.16	0.235	4.005	0.350	760
			22	12.31	0.260	4.030	0.425	880
			26	12.22	0.230	6.490	0.380	1040
			30	12.34	0.260	6.520	0.440	1200
			35	12.50	0.300	6.560	0.520	1400
			40	11.94	0.295	8.005	0.515	1600
			45	12.06	0.335	8.045	0.575	1800
			50	12.19	0.370	8.080	0.640	2000
			53	12.06	0.345	9.995	0.575	2120
			58	12.19	0.360	10.010	0.640	2320
			65	12.12	0.390	12.000	0.605	2600



			72	12.25	0.430	12.040	0.670	2880
			79	12.38	0.470	12.080	0.735	3160
			87	12.53	0.515	12.125	0.810	3480
			96	12.71	0.550	12.160	0.900	3840
			106	12.89	0.610	12.220	0.990	4240
W	14	x	22	13.74	0.230	5.000	0.335	880
			26	13.91	0.255	5.025	0.420	1040
			30	13.84	0.270	6.730	0.385	1200
			34	13.98	0.285	6.745	0.455	1360
			38	14.10	0.310	6.770	0.515	1520
			43	13.66	0.305	7.995	0.530	1720
			48	13.79	0.340	8.030	0.595	1920
			53	13.92	0.370	8.060	0.660	2120
			61	13.89	0.375	9.995	0.645	2440
			74	14.17	0.450	10.070	0.785	2960
			82	14.31	0.510	10.130	0.855	3280
			90	14.02	0.440	14.520	0.710	3600
			99	14.16	0.485	14.565	0.780	3960
			109	14.32	0.525	14.605	0.860	4360
W	16	x	26	15.69	0.250	5.500	0.345	1040
			31	15.88	0.275	5.525	0.440	1240
			36	15.86	0.295	6.985	0.430	1440
			40	16.01	0.305	6.995	0.505	1600
			45	16.13	0.345	7.035	0.565	1800
			50	16.26	0.380	7.070	0.630	2000
			57	16.43	0.430	7.120	0.715	2280
			67	16.33	0.395	10.235	0.665	2680
			77	16.52	0.455	10.295	0.760	3080
			89	16.75	0.525	10.365	0.875	3560
			100	16.97	0.585	10.425	0.985	4000
W	18	x	35	17.70	0.300	6.000	0.425	1400
			40	17.90	0.315	6.015	0.525	1600
			46	18.06	0.360	6.060	0.605	1840
			50	17.99	0.355	7.495	0.570	2000
			55	18.11	0.390	7.530	0.630	2200
			60	18.24	0.415	7.555	0.695	2400
			65	18.35	0.450	7.590	0.750	2600
			71	18.47	0.495	7.635	0.810	2840
			86	18.39	0.480	11.090	0.770	3440
			97	18.59	0.535	11.145	0.870	3880
			106	18.73	0.590	11.200	0.940	4240
			119	18.97	0.655	11.265	1.060	4760
W	21	x	44	20.66	0.350	6.500	0.450	1760
			50	20.83	0.380	6.530	0.535	2000
			57	21.06	0.405	6.555	0.650	2280
			62	20.99	0.400	8.240	0.615	2480
			68	21.13	0.430	8.270	0.685	2720
			73	21.24	0.455	8.295	0.740	2920
			111	21.51	0.550	12.340	0.875	4440
W	24	x	55	23.57	0.395	7.005	0.505	2200
			62	23.74	0.430	7.040	0.590	2480
			68	23.73	0.415	8.965	0.585	2720
			76	23.92	0.440	8.990	0.680	3040
			84	24.10	0.470	9.020	0.770	3360
			94	24.31	0.515	9.065	0.875	3760
			104	24.06	0.500	12.750	0.750	4160
W	27	x	94	26.92	0.490	9.990	0.745	3760
W	30	x	99	29.65	0.520	10.450	0.670	3960

\* Depth may vary within mill tolerances

## Square Tube



Common grade: **ASTM A513 Mechanical tubing (no minimum strength requirements)**  
**ASTM A500 Gr. B.....min. 46,000 yield / min. 58,000 tensile**

Size	Wall Thickness	Weight (lbs.) per Foot	Weight (lbs.) per 20'	Weight (lbs.) per 40'	
1/2	x 1/2	x 0.049	0.283	5.7	11.3
	x 0.065	0.363	7.3	14.5	
5/8	x 5/8	x 0.049	0.363	7.3	14.5
	x 0.065	0.470	9.4	18.8	
3/4	x 3/4	x 0.035	0.340	6.8	13.6
	x 0.049	0.443	8.9	17.7	
	x 0.065	0.557	11.1	22.3	
	x 0.072	0.649	13.0	26.0	
	x 0.083	0.753	15.1	30.1	
	x 0.120	1.028	20.6	41.1	
7/8	x 7/8	x 0.065	0.696	13.9	27.8
	x 0.083	0.894	17.9	35.8	
	x 0.095	1.008	20.2	40.3	
1	x 1	x 0.049	0.627	12.5	25.1
	x 0.065	0.814	16.3	32.6	
	x 0.072	0.893	17.9	35.7	
	x 0.083	1.010	20.2	40.4	
	x 0.095	1.140	22.8	45.6	
	x 0.109	1.250	25.0	50.0	
1 1/4	x 1 1/4	x 0.120	1.390	27.8	55.6
	x 0.049	0.762	15.2	30.5	
	x 0.065	1.040	20.8	41.6	
	x 0.072	1.140	22.8	45.6	
	x 0.083	1.300	26.0	52.0	
	x 0.095	1.470	29.4	58.8	
	x 0.109	1.620	32.4	64.8	
1 1/2	x 1 1/2	x 0.120	1.800	36.0	72.0
	x 0.180	2.340	46.8	93.6	
	x 0.065	1.260	25.2	50.4	
	x 0.072	1.380	27.6	55.2	
	x 0.083	1.580	31.6	63.2	
	x 0.095	1.790	35.8	71.6	
	x 0.109	1.990	39.8	79.6	
	x 0.120	2.210	44.2	88.4	
1 3/4	x 1 3/4	x 0.180	2.950	59.0	118.0
	x 0.250	4.250	85.0	170.0	
	x 0.065	1.469	29.4	58.8	
	x 0.083	1.882	37.6	75.3	
	x 0.095	2.138	42.8	85.5	
	x 0.120	2.660	53.2	106.4	
2	x 2	x 0.065	1.670	33.4	66.8
	x 0.072	1.840	36.8	73.6	
	x 0.083	2.100	42.0	84.0	
	x 0.095	2.380	47.6	95.2	
	x 0.109	2.700	54.0	108.0	
	x 0.120	2.940	58.8	117.6	
	x 0.180	4.170	83.4	166.8	
	x 0.250	5.400	108.0	216.0	
	x 0.095	3.030	60.6	121.2	

2	1/2	x	2	1/2	x	0.109	3.440	68.8	137.6
						0.120	3.760	75.2	150.4
						0.180	5.400	108.0	216.0
						0.250	7.100	142.0	284.0
						0.250	7.562	151.2	302.5
2.53	x		2.53	x					
trailer	hitch		reciever	tube					
3	x		3	x		0.083	3.263	65.3	130.5
						0.095	3.670	73.4	146.8
						0.120	4.570	91.4	182.8
						0.180	6.620	132.4	264.8
						0.250	8.800	176.0	352.0
						0.313	10.580	211.6	423.2
						0.375	12.160	243.2	486.4
						0.109	4.920	98.4	196.8
						0.120	5.390	107.8	215.6
3	1/2	x	3	1/2	x	0.180	7.840	156.8	313.6
						0.250	10.500	210.0	420.0
						0.313	12.700	254.0	508.0
						0.375	14.700	294.0	588.0
						0.095	4.970	99.4	198.8
						0.109	5.660	113.2	226.4
						0.120	6.210	124.2	248.4
						0.180	9.070	181.4	362.8
						0.250	12.200	244.0	488.0
						0.313	14.800	296.0	592.0
						0.375	17.300	346.0	692.0
						0.500	21.600	432.0	864.0
						0.188	10.700	214.0	428.0
						0.250	13.910	278.2	556.4
4	1/2	x	4	1/2	x	0.375	19.830	396.6	793.2
						0.120	7.850	157.0	314.0
						0.188	11.970	239.4	478.8
						0.250	15.620	312.4	624.8
						0.313	19.080	381.6	763.2
						0.375	22.370	447.4	894.8
						0.500	28.430	568.6	1137.2
						0.120	9.860	197.2	394.4
						0.188	14.530	290.6	581.2
						0.250	19.020	380.4	760.8
						0.313	23.340	466.8	933.6
						0.375	27.480	549.6	1099.2
						0.500	35.240	704.8	1409.6
						0.188	17.080	341.6	683.2
						0.250	22.420	448.4	896.8
						0.313	27.590	551.8	1103.6
						0.375	32.580	651.6	1303.2
						0.500	42.050	841.0	1682.0
						0.188	19.630	392.6	785.2
						0.250	25.820	516.4	1032.8
						0.313	31.840	636.8	1273.6
						0.375	37.690	753.8	1507.6
						0.500	48.850	977.0	1954.0
						0.625	59.320	1186.4	2372.8
						0.188	24.730	494.6	989.2
						0.250	32.630	652.6	1305.2
						0.313	40.350	807.0	1614.0
						0.375	47.900	958.0	1916.0
						0.500	62.460	1249.2	2498.4
						0.625	76.330	1526.6	3053.2
						0.188	29.840	596.8	1193.6
10	x		10	x					

				0.250	39.430	788.6	1577.2
12	x	12	x	0.313	48.860	977.2	1954.4
				0.375	58.100	1162.0	2324.0
				0.500	76.070	1521.4	3042.8
				0.625	93.340	1866.8	3733.6
				0.313	57.360	1147.2	2294.4
				0.375	68.310	1366.2	2732.4
14	x	14	x	0.500	89.680	1793.6	3587.2
				0.625	110.360	2207.2	4414.4
				0.313	65.870	1317.4	2634.8
				0.375	78.520	1570.4	3140.8
16	x	16	x	0.500	103.300	2066.0	4132.0
				0.625	127.370	2547.4	5094.8

# Rectangular Tube

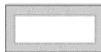

Common grade: **ASTM A513 Mechanical tubing (no minimum strength requirements)**  
**ASTM A500 Gr. B.....min. 46,000 yield / min. 58,000 tensile**

Size				Wall Thickness	Weight (lbs.) per Foot	Weight (lbs.) per 20'	Weight (lbs.) per 40'
1	x	1/2	x	0.049	0.443	8.9	17.7
				0.065	0.577	11.5	23.1
1 1/2	x	3/4	x	0.065	0.898	18.0	35.9
				0.083	1.160	23.2	46.4
1 1/2	x	1	x	0.065	1.010	20.2	40.4
				0.083	1.300	26.0	52.0
				0.095	1.470	29.4	58.8
				0.120	1.800	36.0	72.0
2	x	1	x	0.065	1.260	25.2	50.4
				0.083	1.580	31.6	63.2
				0.095	1.790	35.8	71.6
				0.109	1.990	39.8	79.6
				0.120	2.210	44.2	88.4
2	x	1 1/2	x	0.065	1.490	29.8	59.6
				0.095	2.138	42.8	85.5
				0.120	2.660	53.2	106.4
2 1/2	x	1 1/2	x	0.083	2.100	42.0	84.0
				0.095	2.380	47.6	95.2
				0.109	2.700	54.0	108.0
				0.120	2.940	58.8	117.6
3	x	1	x	0.180	4.320	86.4	172.8
				0.065	1.690	33.8	67.6
				0.083	2.164	43.3	86.6
				0.095	2.380	47.6	95.2
				0.109	2.700	54.0	108.0
3	x	1 1/2	x	0.120	3.050	61.0	122.0
				0.180	4.320	86.4	172.8
				0.083	2.390	47.8	95.6
				0.095	2.700	54.0	108.0
				0.109	3.070	61.4	122.8
3	x	2	x	0.120	3.350	67.0	134.0
				0.180	4.780	95.6	191.2
				0.250	6.250	125.0	250.0
				0.065	2.153	43.1	86.1
				0.083	2.728	54.6	109.1
3 1/2	x	2 1/2	x	0.120	3.760	75.2	150.4
				0.125	3.900	78.0	156.0
				0.188	5.590	111.8	223.6
				0.250	7.110	142.2	284.4
				0.313	8.450	169.0	338.0
4	x	1 1/2	x	0.188	6.880	137.6	275.2
				0.250	8.810	176.2	352.4
4	x	2	x	0.120	4.292	85.8	171.7
				0.083	3.263	65.3	130.5
				0.120	4.580	91.6	183.2
				0.125	4.750	95.0	190.0
				0.188	6.870	137.4	274.8
				0.250	8.810	176.2	352.4
				0.313	10.580	211.6	423.2
			0.375	13.430	268.6	537.2	

4	x	2	1/2	x	0.125	5.175	103.5	207.0	
4	x	3		x	0.120	5.516	110.3	220.6	
					0.125	5.610	112.2	224.4	
					0.188	8.150	163.0	326.0	
					0.250	10.510	210.2	420.4	
					0.313	12.700	254.0	508.0	
					0.375	14.710	294.2	588.4	
4	1/2	x	2	1/2	x	0.250	10.510	210.2	420.4
5	x	2		x	0.120	5.516	110.3	220.6	
					0.125	5.610	112.2	224.4	
					0.134	5.980	119.6	239.2	
					0.188	8.150	163.0	326.0	
					0.250	10.510	210.2	420.4	
					0.313	12.700	254.0	508.0	
5	x	2	1/2	x	0.125	5.924	118.5	237.0	
					0.188	8.880	177.6	355.2	
5	x	3		x	0.120	6.220	124.4	248.8	
					0.188	9.420	188.4	376.8	
					0.250	12.210	244.2	488.4	
					0.313	14.830	296.6	593.2	
					0.375	17.270	345.4	690.8	
					0.500	21.630	432.6	865.2	
5	x	4		x	0.188	10.700	214.0	428.0	
					0.250	13.910	278.2	556.4	
6	x	2		x	0.120	6.220	124.4	248.8	
					0.188	9.420	188.4	376.8	
					0.250	12.210	244.2	488.4	
					0.313	14.830	296.6	593.2	
					0.375	17.270	345.4	690.8	
6	x	3		x	0.120	7.148	143.0	285.9	
					0.188	10.700	214.0	428.0	
					0.250	13.910	278.2	556.4	
					0.313	16.960	339.2	678.4	
					0.375	19.820	396.4	792.8	
					0.500	25.030	500.6	1001.2	
6	x	4		x	0.125	8.160	163.2	326.4	
					0.188	11.970	239.4	478.8	
					0.250	15.620	312.4	624.8	
					0.313	19.080	381.6	763.2	
					0.375	22.370	447.4	894.8	
					0.500	28.430	568.6	1137.2	
7	x	3		x	0.188	11.970	239.4	478.8	
					0.250	15.620	312.4	624.8	
					0.375	22.370	447.4	894.8	
7	x	4		x	0.188	13.250	265.0	530.0	
					0.250	17.320	346.4	692.8	
					0.375	24.930	498.6	997.2	
7	x	5		x	0.188	14.530	290.6	581.2	
					0.250	19.020	380.4	760.8	
					0.313	23.340	466.8	933.6	
					0.375	27.480	549.6	1099.2	
					0.500	35.240	704.8	1409.6	
8	x	2		x	0.188	11.970	239.4	478.8	
					0.250	15.620	312.4	624.8	
					0.375	22.370	447.4	894.8	
8	x	3		x	0.188	13.250	265.0	530.0	
					0.250	17.320	346.4	692.8	
					0.313	21.210	424.2	848.4	
					0.375	24.930	498.6	997.2	
					0.500	31.840	636.8	1273.6	

8	x	4	x	0.188	14.530	290.6	581.2
				0.250	19.020	380.4	760.8
				0.313	23.340	466.8	933.6
				0.375	27.480	549.6	1099.2
8	x	6	x	0.500	35.240	704.8	1409.6
				0.188	17.080	341.6	683.2
				0.250	22.420	448.4	896.8
				0.313	27.590	551.8	1103.6
9	x	5	x	0.375	32.580	651.6	1303.2
				0.500	42.050	841.0	1682.0
				0.188	14.530	290.6	581.2
				0.313	23.340	466.8	933.6
9	x	7	x	0.250	25.820	516.4	1032.8
				0.313	31.840	636.8	1273.6
				0.188	14.530	290.6	581.2
				0.250	19.020	380.4	760.8
10	x	2	x	0.250	20.720	414.4	828.8
				0.188	17.080	341.6	683.2
				0.250	22.420	448.4	896.8
				0.313	27.590	551.8	1103.6
10	x	3	x	0.375	32.580	651.6	1303.2
				0.500	42.050	841.0	1682.0
				0.188	14.530	290.6	581.2
				0.250	19.020	380.4	760.8
10	x	4	x	0.250	20.720	414.4	828.8
				0.188	17.080	341.6	683.2
				0.250	22.420	448.4	896.8
				0.313	27.590	551.8	1103.6
10	x	5	x	0.375	32.580	651.6	1303.2
				0.500	42.050	841.0	1682.0
				0.188	14.530	290.6	581.2
				0.250	19.020	380.4	760.8
10	x	6	x	0.188	17.080	341.6	683.2
				0.250	22.420	448.4	896.8
				0.313	27.590	551.8	1103.6
				0.375	32.580	651.6	1303.2
10	x	8	x	0.500	42.050	841.0	1682.0
				0.250	24.120	482.4	964.8
				0.188	19.630	392.6	785.2
				0.250	25.820	516.4	1032.8
10	x	8	x	0.313	31.840	636.8	1273.6
				0.375	37.690	753.8	1507.6
				0.500	48.850	977.0	1954.0
				0.250	29.230	584.6	1169.2
12	x	2	x	0.375	42.790	855.8	1711.6
				0.500	55.660	1113.2	2226.4
				0.188	17.080	341.6	683.2
				0.250	22.420	448.4	896.8
12	x	3	x	0.250	24.120	482.4	964.8
				0.188	19.630	392.6	785.2
				0.250	25.820	516.4	1032.8
				0.313	31.840	636.8	1273.6
12	x	4	x	0.375	37.690	753.8	1507.6
				0.500	48.850	977.0	1954.0
				0.250	29.230	584.6	1169.2
				0.313	36.100	722.0	1444.0
12	x	6	x	0.375	42.790	855.8	1711.6
				0.500	55.660	1113.2	2226.4
				0.250	24.120	482.4	964.8
				0.313	31.840	636.8	1273.6
12	x	8	x	0.375	42.790	855.8	1711.6
				0.500	55.660	1113.2	2226.4
				0.250	32.630	652.6	1305.2
				0.375	47.900	958.0	1916.0
14	x	4	x	0.500	62.460	1249.2	2498.4
				0.250	29.230	584.6	1169.2
				0.375	47.900	958.0	1916.0
				0.375	58.100	1162.0	2324.0
16	x	8	x	0.375	58.100	1162.0	2324.0
				0.500	76.070	1521.4	3042.8

## Hot Rolled Round Bar



Common grade: ASTM A36.....min. 36,000 yield / min. 58,000 tensile

Size	Weight (lbs.) per Foot	Weight (lbs.) per 20'
------	---------------------------	--------------------------

1/4	0.167	3.3
5/16	0.261	5.2
3/8	0.376	7.5
7/16	0.511	10.2
1/2	0.668	13.4
9/16	0.845	16.9
5/8	1.043	20.9
3/4	1.502	30.0
7/8	2.045	40.9
1	2.670	53.4
1 1/8	3.380	67.6
1 1/4	4.170	83.4
1 3/8	5.050	101.0
1 1/2	6.010	120.2
1 5/8	7.050	141.0
1 3/4	8.180	163.6
1 7/8	9.390	187.8
2	10.680	213.6
2 1/8	12.060	241.2
2 1/4	13.520	270.4
2 3/8	15.060	301.2
2 1/2	16.690	333.8
2 5/8	18.400	368.0
2 3/4	20.190	403.8
3	24.030	480.6
3 1/4	28.210	564.2
3 1/2	32.710	654.2
3 5/8	35.090	701.8
3 3/4	37.550	751.0

Size	Weight (lbs.) per Foot	Weight (lbs.) per 20'
------	---------------------------	--------------------------

4	42.73	854.6
4 1/4	48.23	964.6
4 1/2	54.08	1081.6
4 3/4	60.25	1205.0
5	66.76	1335.2
5 1/4	73.60	1472.0
5 1/2	80.78	1615.6
5 3/4	88.29	1765.8
6	96.13	1922.6
6 1/4	104.31	2086.2
6 1/2	112.82	2256.4
6 3/4	121.67	2433.4
7	130.85	2617.0
7 1/4	140.36	2807.2
7 1/2	150.21	3004.2
7 3/4	160.40	3208.0
8	170.90	3418.0
8 1/4	181.75	3635.0
8 1/2	192.93	3858.6
9	216.30	4326.0
9 1/2	241.00	4820.0
10	267.04	5340.8
10 1/2	294.40	5888.0
12	384.53	7690.6



# Cold Drawn Round Bar



Common grade: ASTM A108 Grade 1018

Size	Weight (lbs.) per Foot	Weight (lbs.) per 20'
1/8	0.042	0.840
3/16	0.094	1.880
1/4	0.167	3.340
5/16	0.261	5.220
3/8	0.376	7.520
7/16	0.511	10.220
1/2	0.668	13.360
9/16	0.845	16.900
5/8	1.043	20.860
11/16	1.262	25.240
3/4	1.502	30.040
13/16	1.763	35.260
7/8	2.045	40.900
15/16	2.347	46.940
1	2.670	53.400
1 1/16	3.010	60.200
1 1/8	3.380	67.600
1 3/16	3.766	75.320
1 1/4	4.172	83.440
1 5/16	4.600	92.000
1 3/8	5.049	100.980
1 7/16	5.520	110.400
1 1/2	6.010	120.200
1 9/16	6.520	130.400
1 5/8	7.050	141.000
1 11/16	7.600	152.000
1 3/4	8.180	163.600
1 13/16	8.770	175.400
1 7/8	9.390	187.800
1 15/16	10.020	200.400
2	10.680	213.600
2 1/16	11.360	227.200
2 1/8	12.060	241.200
2 3/16	12.780	255.600
2 1/4	13.520	270.400
2 5/16	14.28	285.60
2 3/8	15.06	301.20
2 7/16	15.87	317.40
2 1/2	16.69	333.80
2 9/16	17.53	350.60
2 5/8	18.40	368.00
2 11/16	19.29	385.80

Size	Weight (lbs.) per Foot	Weight (lbs.) per 20'
4	42.72	854.40
4 1/8	45.43	908.63
4 3/16	46.82	936.38
4 1/4	48.23	964.54
4 5/16	49.66	993.11
4 3/8	51.11	1022.11
4 7/16	52.58	1051.52
4 1/2	54.07	1081.35
4 9/16	55.58	1111.60
4 5/8	57.11	1142.26
4 11/16	58.67	1173.34
4 3/4	60.24	1204.84
4 7/8	63.45	1269.08
4 15/16	65.09	1301.83
5	66.75	1335.00
5 1/16	68.43	1368.58
5 1/8	70.13	1402.58
5 3/16	71.85	1437.00
5 1/4	73.59	1471.84
5 3/8	77.14	1542.76
5 7/16	78.94	1578.85
5 1/2	80.77	1615.35
5 5/8	84.48	1689.61
5 3/4	88.28	1765.54
5 7/8	92.16	1843.13
5 15/16	94.13	1882.56
6	96.12	1922.40
6 1/4	104.30	2085.94
6 1/2	112.81	2256.15
6 3/4	121.65	2433.04
7	130.83	2616.60
7 1/2	150.19	3003.75
8	170.88	3417.60
9	216.27	4325.40
10	267.00	5340.00

## Hot Rolled Strip

Common grade: ASTM A36.....min. 36,000 yield / min. 58,000 tensile

Size	Weight (lbs.) per Foot	Weight (lbs.) per 20'
1/8 x 1/2	0.213	4.25
3/4	0.319	6.38
1	0.425	8.51
1 1/4	0.532	10.64
1 1/2	0.638	12.76
1 3/4	0.744	14.89
2	0.851	17.02
2 1/4	0.957	19.14
2 1/2	1.064	21.27
2 3/4	1.170	23.40
3	1.276	25.52
3 1/4	1.383	27.65
3 1/2	1.489	29.78
4	1.702	34.03
4 1/2	1.914	38.29
5	2.127	42.54
5 1/2	2.340	46.79
6	2.552	51.05
8	3.403	68.06
10	4.254	85.08
12	5.105	102.10

Size	Weight (lbs.) per Foot	Weight (lbs.) per 20'
3/16 x 1/2	0.319	6.38
3/4	0.479	9.57
1	0.638	12.76
1 1/4	0.798	15.95
1 1/2	0.957	19.14
1 3/4	1.117	22.33
2	1.276	25.52
2 1/4	1.436	28.71
2 1/2	1.595	31.91
3	1.914	38.29
3 1/4	2.074	41.48
3 1/2	2.233	44.67
4	2.552	51.05
4 1/2	2.871	57.43
5	3.191	63.81
6	3.829	76.57
7	4.467	89.33
8	5.105	102.10
9	5.743	114.86
10	6.381	127.62
12	7.657	153.14

## Hot Rolled Flat Bar

Common grade: ASTM A36.....min. 36,000 yield / min. 58,000 tensile



Size	Weight (lbs.) per Foot	Weight (lbs.) per 20'
1/4 x 1/2	0.43	8.51
5/8	0.53	10.64
3/4	0.64	12.76
7/8	0.74	14.89
1	0.85	17.02
1 1/4	1.06	21.27
1 1/2	1.28	25.52
1 3/4	1.49	29.78
2	1.70	34.03
2 1/4	1.91	38.29
2 1/2	2.13	42.54
2 3/4	2.34	46.79
3	2.55	51.05
3 1/2	2.98	59.56
4	3.40	68.06
4 1/2	3.83	76.57
5	4.25	85.08
5 1/2	4.68	93.59
6	5.10	102.10
7	5.96	119.11
8	6.81	136.13
5/16 x 1/2	0.53	10.64
3/4	0.80	15.95
1	1.06	21.27
1 1/4	1.33	26.59
1 1/2	1.60	31.91
1 3/4	1.86	37.22
2	2.13	42.54
2 1/4	2.39	47.86
2 1/2	2.66	53.18
3	3.19	63.81
3 1/2	3.72	74.45
4	4.25	85.08
4 1/2	4.79	95.72
5	5.32	106.35
5 1/2	5.85	116.99
6	6.38	127.62
7	7.44	148.89
8	8.51	170.16
3/8 x 1/2	0.64	12.76
3/4	0.96	19.14
1	1.28	25.52
1 1/4	1.60	31.91
1 1/2	1.91	38.29
1 3/4	2.23	44.67
2	2.55	51.05
2 1/4	2.87	57.43
2 1/2	3.19	63.81
2 3/4	3.51	70.19
3	3.83	76.57
3 1/2	4.47	89.33
4	5.10	102.10
4 1/2	5.74	114.86
5	6.38	127.62
5 1/2	7.02	140.38
6	7.66	153.14
7	8.93	178.67
8	10.21	204.19

Size	Weight (lbs.) per Foot	Weight (lbs.) per 20'
3/4 x 1	2.55	51.05
1 1/4	3.19	63.81
1 1/2	3.83	76.57
1 3/4	4.47	89.33
2	5.10	102.10
2 1/4	5.74	114.86
2 1/2	6.38	127.62
2 3/4	7.02	140.38
3	7.66	153.14
3 1/2	8.93	178.67
4	10.21	204.19
4 1/2	11.49	229.72
5	12.76	255.24
5 1/2	14.04	280.76
6	15.31	306.29
7	17.87	357.34
8	20.42	408.38
1 x 1 1/4	4.25	85.08
1 1/2	5.10	102.10
1 3/4	5.96	119.11
2	6.81	136.13
2 1/4	7.66	153.14
2 1/2	8.51	170.16
2 3/4	9.36	187.18
3	10.21	204.19
3 1/2	11.91	238.22
4	13.61	272.26
4 1/2	15.31	306.29
5	17.02	340.32
5 1/2	18.72	374.35
6	20.42	408.38
7	23.82	476.45
8	27.23	544.51
1 1/4 x 2	8.51	170.16
2 1/4	9.57	191.43
2 1/2	10.64	212.70
2 3/4	11.70	233.97
3	12.76	255.24
3 1/2	14.89	297.78
4	17.02	340.32
4 1/2	19.14	382.86
5	21.27	425.40
5 1/2	23.40	467.94
6	25.52	510.48
7	29.78	595.56
8	34.03	680.64
1 1/2 x 2	10.21	204.19
2 1/4	11.49	229.72
2 1/2	12.76	255.24
2 3/4	14.04	280.76
3	15.31	306.29
3 1/2	17.87	357.34
4	20.42	408.38
4 1/2	22.97	459.43
5	25.52	510.48
5 1/2	28.08	561.53
6	30.63	612.58
7	35.73	714.67

1/2	x	3/4	1.28	25.52	8	40.84	816.77		
		1	1.70	34.03	2	x	2 1/2	17.02	340.32
		1 1/4	2.13	42.54			3	20.42	408.38
		1 1/2	2.55	51.05			3 1/2	23.82	476.45
		1 3/4	2.98	59.56			4	27.23	544.51
		2	3.40	68.06			5	34.03	680.64
		2 1/4	3.83	76.57			6	40.84	816.77
		2 1/2	4.25	85.08			7	47.64	952.90
		2 3/4	4.68	93.59			8	54.45	1089.02
		3	5.10	102.10					
		3 1/2	5.96	119.11					
		4	6.81	136.13					
		4 1/2	7.66	153.14					
		5	8.51	170.16					
		5 1/2	9.36	187.18					
		6	10.21	204.19					
		7	11.91	238.22					
		8	13.61	272.26					
5/8	x	1	2.13	42.54					
		1 1/4	2.66	53.18					
		1 1/2	3.19	63.81					
		1 3/4	3.72	74.45					
		2	4.25	85.08					
		2 1/4	4.79	95.72					
		2 1/2	5.32	106.35					
		2 3/4	5.85	116.99					

# Cold Drawn Flat Bar



Common grade: ASTM A108 Grade 1018

Size	Weight (lbs.) per Foot	Weight (lbs.) per 12'	Size	Weight (lbs.) per Foot	Weight (lbs.) per 12'	
1/8 x	1/4	0.11	5/8 x	3/4	1.60	
	3/8	0.16		1	2.13	
	1/2	0.21		1 1/4	2.66	
	5/8	0.27		1 1/2	3.19	
	3/4	0.32		1 3/4	3.72	
	1	0.43		2	4.25	
	1 1/4	0.53		2 1/4	4.79	
	1 1/2	0.64		2 1/2	5.32	
	1 3/4	0.74		2 3/4	5.85	
	2	0.85		3	6.38	
	2 1/4	0.96		3 1/2	7.44	
	2 1/2	1.06		4	8.51	
	2 3/4	1.17		4 1/2	9.57	
	3	1.28		5	10.64	
	3 1/2	1.49		6	12.76	
	4	1.70		8	17.02	
	4 1/2	1.91		10	21.27	
5	2.13	12	25.52			
3/16 x	1/4	0.16	3/4 x	1	2.55	
	3/8	0.24		1 1/4	3.19	
	1/2	0.32		1 1/2	3.83	
	5/8	0.40		1 3/4	4.47	
	3/4	0.48		2	5.10	
	1	0.64		2 1/4	5.74	
	1 1/4	0.80		2 1/2	6.38	
	1 1/2	0.96		2 3/4	7.02	
	1 3/4	1.12		3	7.66	
	2	1.28		3 1/2	8.93	
	2 1/4	1.44		4	10.21	
	2 1/2	1.60		4 1/2	11.49	
	2 3/4	1.75		5	12.76	
	3	1.91		6	15.31	
	3 1/2	2.23		8	20.42	
	4	2.55		10	25.52	
	4 1/2	2.87		12	30.63	
5	3.19	1 x	1 1/4	4.25		
6	3.83		1 1/2	5.10		
8	5.10		1 3/4	5.96		
1/4 x	3/8		0.32	2	6.81	
	1/2		0.43	2 1/4	7.66	
	5/8		0.53	2 1/2	8.51	
	3/4		0.64	2 3/4	9.36	
	1		0.85	3	10.21	
	1 1/4		1.06	3 1/2	11.91	
	1 1/2		1.28	4	13.61	
	1 3/4		1.49	4 1/2	15.31	
	2		1.70	5	17.02	
	2 1/4		1.91	6	20.42	
	2 1/2		2.13	8	27.23	
	2 3/4		2.34	10	34.03	
	3		2.55	1 1/4 x	1 1/2	6.38
	3 1/2		2.98		1 3/4	7.44
			2		8.51	

	4	3.40	40.84		2 1/4	9.57	114.86
	4 1/2	3.83	45.94		2 1/2	10.64	127.62
	5	4.25	51.05		2 3/4	11.70	140.38
	6	5.10	61.26		3	12.76	153.14
	8	6.81	81.68		3 1/2	14.89	178.67
5/16 x	1/2	0.53	6.38		4	17.02	204.19
	5/8	0.66	7.98		4 1/2	19.14	229.72
	3/4	0.80	9.57		5	21.27	255.24
	1	1.06	12.76		6	25.52	306.29
	1 1/4	1.33	15.95		8	34.03	408.38
	1 1/2	1.60	19.14		10	42.54	510.48
	1 3/4	1.86	22.33	1 1/2 x	1 3/4	8.93	107.20
	2	2.13	25.52		2	10.21	122.52
	2 1/4	2.39	28.71		2 1/4	11.49	137.83
	2 1/2	2.66	31.91		2 1/2	12.76	153.14
	2 3/4	2.92	35.10		2 3/4	14.04	168.46
	3	3.19	38.29		3	15.31	183.77
	3 1/2	3.72	44.67		3 1/2	17.87	214.40
	4	4.25	51.05		4	20.42	245.03
	4 1/2	4.79	57.43		4 1/2	22.97	275.66
	5	5.32	63.81		5	25.52	306.29
	6	6.38	76.57		6	30.63	367.55
	8	8.51	102.10		8	40.84	490.06
3/8 x	1/2	0.64	7.66		10	51.05	612.58
	5/8	0.80	9.57	1 3/4 x	2	11.91	142.93
	3/4	0.96	11.49		2 1/4	13.40	160.80
	1	1.28	15.31		2 1/2	14.89	178.67
	1 1/4	1.60	19.14		2 3/4	16.38	196.53
	1 1/2	1.91	22.97		3	17.87	214.40
	1 3/4	2.23	26.80		3 1/2	20.84	250.14
	2	2.55	30.63		4	23.82	285.87
	2 1/4	2.87	34.46		4 1/2	26.80	321.60
	2 1/2	3.19	38.29		5	29.78	357.34
	2 3/4	3.51	42.11		6	35.73	428.80
	3	3.83	45.94		8	47.64	571.74
	3 1/2	4.47	53.60		10	59.56	714.67
	4	5.10	61.26	2 x	2 1/4	15.31	183.77
	4 1/2	5.74	68.91		2 1/2	17.02	204.19
	5	6.38	76.57		2 3/4	18.72	224.61
	6	7.66	91.89		3	20.42	245.03
	8	10.21	122.52		3 1/2	23.82	285.87
	10	12.76	153.14		4	27.23	326.71
	12	15.31	183.77		4 1/2	30.63	367.55
1/2 x	5/8	1.06	12.76		5	34.03	408.38
	3/4	1.28	15.31		6	40.84	490.06
	1	1.70	20.42		8	54.45	653.41
	1 1/4	2.13	25.52		10	68.06	816.77
	1 1/2	2.55	30.63				
	1 3/4	2.98	35.73				
	2	3.40	40.84				
	2 1/4	3.83	45.94				
	2 1/2	4.25	51.05				
	2 3/4	4.68	56.15				
	3	5.10	61.26				
	3 1/2	5.96	71.47				
	4	6.81	81.68				
	4 1/2	7.66	91.89				
	5	8.51	102.10				
	6	10.21	122.52				
	8	13.61	163.35				
	10	17.02	204.19				
	12	20.42	245.03				

# Hot Rolled Square Bar



Common grade: ASTM A36.....min. 36,000 yield / min. 58,000 tensile

Size	Weight (lbs.) per Foot	Weight (lbs.) per 20'
1/4	0.21	4.25
3/8	0.48	9.57
1/2	0.85	17.02
5/8	1.33	26.59
3/4	1.91	38.29
7/8	2.61	52.11
1	3.40	68.06
1 1/8	4.31	86.14
1 1/4	5.32	106.35
1 3/8	6.43	128.68
1 1/2	7.66	153.14
1 5/8	8.99	179.73
1 3/4	10.42	208.45
1 7/8	11.96	239.29
2	13.61	272.26
2 1/4	17.23	344.57
2 1/2	21.27	425.40
2 5/8	23.45	469.00
2 3/4	25.74	514.73
3	30.63	612.58
3 1/4	35.95	718.93
3 1/2	41.69	833.78
4	54.45	1089.02
4 1/2	68.91	1378.30
5	85.08	1701.60
6	122.52	2450.30

# Cold Drawn Square Bar



Common grade: ASTM A108 Grade 1018

Size	Weight (lbs.) per Foot	Weight (lbs.) per 12'
1/8	0.05	0.64
3/16	0.12	1.44
1/4	0.21	2.55
5/16	0.33	3.99
3/8	0.48	5.74
7/16	0.65	7.82
1/2	0.85	10.21
9/16	1.08	12.92
5/8	1.33	15.95
11/16	1.61	19.30
3/4	1.91	22.97
13/16	2.25	26.96
7/8	2.61	31.27
15/16	2.99	35.89
1	3.40	40.84
1 1/16	3.84	46.10
1 1/8	4.31	51.69
1 3/16	4.80	57.59
1 1/4	5.32	63.81
1 3/8	6.43	77.21
1 1/2	7.66	91.89
1 3/4	10.42	125.07
2	13.61	163.35
2 1/4	17.23	206.74
2 1/2	21.27	255.24
2 5/8	23.45	281.40
2 3/4	25.74	308.84
3	30.63	367.55



# Cold Drawn Hex Bar



Common grade: ASTM A108 Grade 1018

Size	Weight (lbs.) per Foot	Weight (lbs.) per 12'
1/4	0.184	2.21
3/8	0.414	4.97
7/16	0.564	6.77
1/2	0.736	8.83
9/16	0.932	11.18
5/8	1.150	13.80
11/16	1.392	16.70
3/4	1.656	19.87
13/16	1.944	23.33
7/8	2.254	27.05
15/16	2.588	31.06
1	2.945	35.34
1 1/16	3.324	39.89
1 1/8	3.727	44.72
1 1/4	4.601	55.21
1 5/16	5.072	60.86
1 3/8	5.567	66.80
1 1/2	6.625	79.50
1 5/8	7.775	93.30
1 11/16	8.385	100.62
1 3/4	9.018	108.22
1 7/8	10.350	124.20
2	11.780	141.36
2 1/4	14.910	178.92
2 3/8	16.610	199.32
2 1/2	18.400	220.80
2 5/8	20.290	243.48
2 3/4	22.270	267.24
3	26.500	318.00
3 1/2	36.080	432.96
3 3/4	41.410	496.92
4	47.120	565.44

## UM Plate (Universal Mill Plate)

Common grade: ASTM A36.....min. 36,000 yield / min. 58,000 tensile

Size			Weight (lbs.) per Foot	Weight (lbs.) per 20'
1/4	x	9	7.66	153.1
		10	8.51	170.2
		12	10.21	204.2
5/16	x	9	9.57	191.4
		10	10.64	212.7
		12	12.76	255.2
3/8	x	9	11.49	229.7
		10	12.76	255.2
		12	15.31	306.3
1/2	x	9	15.31	306.3
		10	17.02	340.3
		12	20.42	408.4
5/8	x	9	19.14	382.9
		10	21.27	425.4
		12	25.52	510.5
3/4	x	9	22.97	459.4
		10	25.52	510.5
		12	30.63	612.6
1	x	9	30.63	612.6
		10	34.03	680.6
		12	40.84	816.8
1 1/4	x	10	42.54	850.8
		12	51.05	1021.0
1 1/2	x	10	51.05	1021.0
		12	61.26	1225.2

## Standard (Raised) Expanded Metal

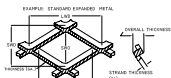

Style	Weight (lbs.) Per Sq. Ft.	Opening SWO	Size LWO	Open Area %	Strand Width	Strand Thickness	Overall Thickness
1/2 No. 20	0.43	0.438	0.938	80	0.072	0.036	0.14
1/2 No. 18	0.70	0.438	0.938	72	0.088	0.048	0.172
1/2 No. 16	0.86	0.375	0.938	65	0.087	0.06	0.175
1/2 No. 13	1.47	0.312	0.938	57	0.096	0.09	0.204
3/4 No. 16	0.54	0.813	1.75	78	0.101	0.06	0.21
3/4 No. 13	0.80	0.750	1.688	76	0.096	0.09	0.205
3/4 No. 10	1.20	0.750	1.625	72	0.144	0.09	0.29
3/4 No. 9	1.80	0.688	1.562	68	0.15	0.135	0.312
1 No. 16	0.47	0.938	2	82	0.087	0.06	0.192
1 1/2 No. 16	0.40	1.250	2.625	85	0.108	0.06	0.23
1 1/2 No. 13	0.60	1.888	2.5	85	0.105	0.09	0.242
1 1/2 No. 9	1.20	1.125	2.375	76	0.144	0.135	0.312
1 1/2 No. 6	2.50	1.110	2.313	69	0.203	0.198	0.433

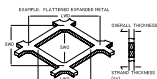

## Flattened Expanded Metal

Style	Weight (lbs.) Per Sq. Ft.	Opening SWO	Size LWO	Open Area %	Strand Width	Strand Thickness
1/2 No. 18	0.66	0.312	1	60	0.097	0.039
1/2 No. 16	0.82	0.312	1	63	0.096	0.056
1/2 No. 13	1.40	0.312	1	52	0.107	0.07
3/4 No. 16	0.51	0.750	1.75	74	0.111	0.048
3/4 No. 13	0.75	0.688	1.781	74	0.106	0.07
3/4 No. 10	1.14	0.637	1.755	68	0.16	0.07
3/4 No. 9	1.71	0.563	1.688	63	0.165	0.12

## Plate Grades \*

<b>A36</b>	Most common grade of steel plate used for general structural purposes Minimum yield of 36,000 psi/ minimum tensile of 58,000 psi
<b>A131</b>	ABS plate is intended primarily for use in shipbuilding. Minimum yield of 34,000 psi/ minimum tensile of 58,000 psi
<b>A514</b>	(T-1) quenched and tempered alloy plate 2-1/2" thick and under, minimum yield 100,000 psi/ tensile 110-130,000 psi Over 2-1/2" thick, minimum yield 90,000 psi/ tensile 100-130,000 psi
<b>A516</b>	Pressure vessel plate Grade 55, tensile strength 55-75,000 psi Grade 60, tensile strength 60-80,000 psi Grade 65, tensile strength 65-85,000 psi Grade 70, tensile strength 70-90,000 psi
<b>A572 Gr. 50</b>	High-strength low-alloy plate Grade 42, minimum yield of 42,000 psi/ minimum tensile of 60,000 psi Grade 50, minimum yield of 50,000 psi/ minimum tensile of 65,000 psi Grade 55, minimum yield of 55,000 psi/ minimum tensile of 70,000 psi Grade 60, minimum yield of 60,000 psi/ minimum tensile of 75,000 psi Grade 65, minimum yield of 65,000 psi/ minimum tensile of 80,000 psi
<b>A588</b>	(Corten) high-strength low-alloy with extra corrosion resistance properties 4" thick and under, minimum yield 50,000 psi/ minimum tensile 70,000 psi Over 4" to 5" thick, minimum yield 46,000 psi/ minimum tensile 67,000 psi Over 5" thick, minimum yield 42,000 psi/ minimum tensile 63,000 psi
<b>A656</b>	High-strength low-alloy plate offering improved formability Grade 50, minimum yield of 50,000 psi/ minimum tensile of 60,000 psi Grade 60, minimum yield of 60,000 psi/ minimum tensile of 70,000 psi Grade 70, minimum yield of 70,000 psi/ minimum tensile of 80,000 psi Grade 80, minimum yield of 80,000 psi/ minimum tensile of 90,000 psi
<b>A786</b>	Floor plate
<b>AR</b>	Abrasion resistant plate also offering great impact strength AR 235, Brinell hardness approximately 212-255 AR 400, Brinell hardness minimum 360 AR 500, Brinell hardness 500 nominal

## Sheet Grades

<b>A 1011</b>	CS Type B, formerly referred to as A569/ Hot-rolled commercial steel sheet
<b>A 1011</b>	SS Grade 36, formerly referred to as A570 Gr. 36/ Hot-rolled structural steel sheet
<b>A 1011</b>	HSLA Grade 50, formerly referred to as A607 Gr. 50/ Hot-rolled high-strength, low-alloy sheet
<b>A 1008</b>	Cold-rolled structural, high-strength low-alloy (HSLA) and HSLA with improved formability steel sheet

\* Does not include all plate and sheet grades

## Weight Per Plate



Thickness	Plate Size	Weight Per Plate	
7.66# / Sq. Ft.	<b>3/16"</b>	245.05	
	48 x 120	306.32	
	48 x 144	367.58	
	48 x 240	612.63	
	<b>60</b> x 96	306.32	
	60 x 120	382.90	
	60 x 144	459.47	
	60 x 240	765.79	
	60 x 360	1148.69	
	<b>72</b> x 96	367.58	
	72 x 120	459.47	
	72 x 144	551.37	
72 x 240	918.95		
72 x 360	1378.42		
10.21# / Sq. Ft.	<b>84</b> x 96	428.84	
	84 x 120	536.05	
	84 x 144	643.26	
	84 x 240	1072.11	
	84 x 360	1608.16	
	<b>96</b> x 120	612.63	
	96 x 144	735.16	
	96 x 240	1225.26	
	96 x 360	1837.90	
	<b>1/4"</b>	48 x 96	326.71
	48 x 120	408.38	
	48 x 144	490.06	
48 x 240	816.77		
15.32# / Sq. Ft.	<b>60</b> x 96	408.38	
	60 x 120	510.48	
	60 x 144	612.58	
	60 x 240	1020.96	
	60 x 360	1531.44	
	<b>72</b> x 96	490.06	
	72 x 120	612.58	
	72 x 144	735.09	
	72 x 240	1225.15	
	72 x 360	1837.73	
	<b>5/16"</b>	120 x 240	2552.24
	120 x 360	3828.82	
120 x 480	5104.48		
15.31# / Sq. Ft.	<b>3/8"</b>	48 x 96	490.06
	48 x 120	612.58	
	48 x 144	735.09	

Thickness	Plate Size	Weight Per Plate	
10.21# / Sq. Ft.	<b>1/4"</b>	84 x 96	571.74
	84 x 120	714.67	
	84 x 144	857.61	
	84 x 240	1429.34	
	84 x 360	2144.02	
	<b>96</b> x 120	816.77	
	96 x 144	980.12	
	96 x 240	1633.54	
	96 x 360	24150.30	
	96 x 480	3267.07	
	<b>120</b> x 240	2041.92	
	120 x 360	3062.88	
120 x 480	4083.84		
7.68# / Sq. Ft.	<b>5/16"</b>	48 x 96	408.41
	48 x 120	510.51	
	48 x 144	612.61	
	48 x 240	1021.02	
	<b>60</b> x 96	510.51	
	60 x 120	638.14	
	60 x 144	765.76	
	60 x 240	1276.27	
	60 x 360	1914.41	
	<b>72</b> x 96	612.61	
	72 x 120	765.76	
	72 x 144	918.92	
72 x 240	1531.53		
72 x 360	2297.29		
20.42# / Sq. Ft.	<b>84</b> x 96	714.71	
	84 x 120	893.39	
	84 x 144	1072.07	
	84 x 240	1786.78	
	84 x 360	2680.17	
	<b>96</b> x 120	1021.02	
	96 x 144	1225.22	
	96 x 240	2042.04	
	96 x 360	3063.05	
	96 x 480	4084.08	
	<b>1/2"</b>	72 x 96	980.12
	72 x 120	1225.15	
72 x 144	1470.18		
72 x 240	2450.30		
72 x 360	3675.46		
15.31# / Sq. Ft.	<b>84</b> x 96	1143.48	

Thickness	Plate Size	Weight Per Plate
	48 x 240	1225.15
	<b>60</b> x 96	612.58
	60 x 120	765.72
	60 x 144	918.86
	60 x 240	1531.44
	60 x 360	2297.16
	<b>72</b> x 96	735.09
	72 x 120	918.86
	72 x 144	1102.64
	72 x 240	1837.73
	72 x 360	2756.59
	<b>84</b> x 96	857.61
	84 x 120	1072.01
	84 x 144	1286.41
	84 x 240	2144.02
	84 x 360	3216.02
	<b>96</b> x 120	1225.15
	96 x 144	1470.18
	96 x 240	2450.30
	96 x 360	3675.46
	96 x 480	4900.61
	<b>120</b> x 240	3062.88
	120 x 360	4594.32
	120 x 480	6125.76
<b>1/2"</b>	<b>48</b> x 96	653.41
	48 x 120	816.77
20.42# / Sq. Ft.	48 x 144	980.12
	48 x 240	1633.54
	<b>60</b> x 96	816.77
	60 x 120	1020.96
	60 x 144	1225.15
	60 x 240	2041.92
	60 x 360	3062.88
<b>3/4"</b>	<b>72</b> x 96	1470.18
	72 x 120	1837.73
30.63# / Sq. Ft.	72 x 144	2205.27
	72 x 240	3675.46
	72 x 360	5513.18
	<b>84</b> x 96	1715.22
	84 x 120	2144.02
	84 x 144	2572.82
	84 x 240	4288.03
	84 x 360	6432.05
	<b>96</b> x 120	2450.31
	96 x 144	2940.36
	96 x 240	4900.61

Thickness	Plate Size	Weight Per Plate
	84 x 120	1429.34
	84 x 144	1715.21.
	84 x 240	2858.69
	84 x 360	4288.03
	<b>96</b> x 120	1633.54
	96 x 144	1960.25
	96 x 240	3267.07
	96 x 360	4900.61
	96 x 480	6534.14
	<b>120</b> x 240	4083.84
	120 x 360	6125.76
	120 x 480	8167.68
<b>5/8"</b>	<b>48</b> x 96	816.77
	48 x 120	1020.96
25.53# / Sq. Ft.	<b>60</b> x 120	1276.20
	60 x 240	2552.40
	<b>72</b> x 120	1531.44
	72 x 240	3062.88
	<b>84</b> x 120	1786.68
	84 x 240	3573.36
	<b>96</b> x 120	2041.92
	96 x 240	4083.84
	96 x 360	6125.76
<b>3/4"</b>	<b>48</b> x 96	980.12
	48 x 120	1225.15
30.63# / Sq. Ft.	48 x 144	1470.18
	48 x 240	2450.30
	<b>60</b> x 96	1225.15
	60 x 120	1531.44
	60 x 144	1837.73
	60 x 240	3062.88
	60 x 360	4594.32
<b>1"</b>	<b>60</b> x 96	1633.54
	60 x 120	2041.92
40.84# / Sq. Ft.	60 x 144	2450.30
	60 x 240	4083.84
	60 x 360	6125.76
	<b>72</b> x 96	1960.24
	72 x 120	2450.30
	72 x 144	2940.36
	72 x 240	4900.61
	72 x 360	7350.91
	<b>84</b> x 96	2286.95
	84 x 120	2858.69
	84 x 144	3430.43

	96 x 360	7350.91		84 x 240	5717.38
	96 x 480	9801.22		84 x 360	8576.06
	<b>120</b> x 240	6125.76		<b>96</b> x 120	3267.07
	120 x 360	9188.64		96 x 144	3920.49
	120 x 480	12251.52		96 x 240	6534.14
				96 x 360	9801.22
<b>7/8"</b>	<b>48</b> x 96	1143.48		96 x 480	13068.29
	48 x 120	1429.35			
35.74# / Sq. Ft.	48 x 144	1715.21		<b>120</b> x 240	8167.68
	48 x 240	2858.69		120 x 360	12251.52
				120 x 480	16335.36
	<b>60</b> x 96	1429.34			
	60 x 120	1786.68		<b>1-1/4"</b>	
	60 x 144	2144.02		48 x 96	1633.53
	60 x 240	3573.36	51.05# / Sq. Ft.	48 x 120	2041.92
				<b>60</b> x 120	2552.40
	<b>72</b> x 120	2144.02		60 x 240	5104.80
	72 x 240	4288.03			
				<b>72</b> x 120	3062.88
	84 x 120	2501.35		72 x 240	6125.76
	84 x 240	5002.70			
				<b>84</b> x 120	3573.36
	<b>96</b> x 120	2858.69		84 x 240	7146.72
	96 x 240	5717.38			
	96 x 360	8576.06		<b>96</b> x 120	4083.44
				96 x 240	8167.68
<b>1"</b>	<b>48</b> x 96	1306.83		96 x 360	12251.52
	48 x 120	1633.54			
40.84# / Sq. Ft.	48 x 144	1960.24			
	48 x 240	3267.08			

Thickness	Plate Size	Weight Per Plate
1-1/2" 61.26# / Sq. Ft.	48 x 96	1960.24
	48 x 120	2450.30
	60 x 120	3062.88
	60 x 240	6125.76
	72 x 120	3675.45
	72 x 240	7350.91
	84 x 120	4288.03
	84 x 240	8576.06
	96 x 120	4900.60
	96 x 240	9801.22
	96 x 360	14701.80
	1-3/4" 71.47# / Sq. Ft.	48 x 96
48 x 120		2858.68
60 x 120		3573.36
60 x 240		7146.72
72 x 120		4288.03
72 x 240		8576.06
84 x 120		5002.70
84 x 240		10005.41
96 x 120		5717.37
96 x 240		11434.75
96 x 360		17152.13
2" 81.68# / Sq. Ft.		48 x 96
	48 x 120	3267.07
	60 x 120	4083.84
	60 x 240	8167.68
	72 x 120	4900.61
	72 x 240	9801.22
	84 x 120	5717.37
	84 x 240	11434.75
	96 x 120	6534.14
	96 x 240	13068.29
	96 x 360	19602.43



# Floor Plate



Common grade: ASTM A786

Thickness	Weight (lbs.) per Sq.Ft
16 Gauge	3.00
14 Gauge	3.75
12 Gauge	5.25
1/8	6.16
3/16	8.71
1/4	11.26
5/16	13.81
3/8	16.37
1/2	21.47
5/8	26.55
3/4	31.65
1	41.90

## Weight Per Sheet

### Hot Rolled Sheets

Thickness	Plate Size	Weight Per Sheet
<b>10 ga. (.1345)</b>	48 x 96	180.00
	48 x 120	225.00
<b>5.625#/Sq. Ft.</b>	48 x 144	270.00
	48 x 240	450.00
	60 x 96	225.00
	60 x 120	281.30
	60 x 144	337.50
	60 x 240	562.50
	72 x 96	270.00
	72 x 120	337.50
	72 x 144	405.00
	72 x 240	675.00
	84 x 120	393.80
	84 x 144	472.50
	84 x 240	787.50
<b>11 ga. (.1196)</b>	48 x 96	160.00
	48 x 120	200.00
<b>5.0# / Sq. Ft.</b>	48 x 144	240.00
	48 x 240	400.00
	60 x 96	200.00
	60 x 120	250.00
	60 x 144	300.00
	60 x 240	500.00
	72 x 96	240.00
	72 x 120	300.00
	72 x 144	360.00
	72 x 240	600.00
<b>12 ga. (.1046)</b>	48 x 96	140.00
	48 x 120	175.00
<b>4.375# / Sq. Ft.</b>	48 x 144	210.00
	48 x 240	350.00
	60 x 96	175.00
	60 x 120	218.80
	60 x 144	262.50
	60 x 240	437.50

### Cold Rolled Sheets

Thickness	Plate Size	Weight Per Sheet
<b>16 ga. (.0598)</b>	48 x 96	80.00
	48 x 120	100.00
<b>2.5# / Sq. Ft.</b>	48 x 144	120.00
	60 x 96	100.00
	60 x 120	125.00
<b>18 ga. (.0478)</b>	48 x 96	64.00
	48 x 120	80.00
<b>2.0# / Sq. Ft.</b>	48 x 144	96.00
<b>20 ga. (.0359)</b>	36 x 96	36.00
	36 x 120	45.00
<b>1.50# / Sq. Ft.</b>	48 x 96	48.00
	48 x 120	60.00
	48 x 144	72.00
<b>22 ga. (.0299)</b>	36 x 96	30.00
	36 x 120	37.00
<b>1.25# / Sq. Ft.</b>	48 x 96	40.00
	48 x 120	50.00
<b>24 ga. (.0239)</b>	36 x 96	24.00
	36 x 120	30.00
<b>1.0# / Sq. Ft.</b>	48 x 96	32.00
	48 x 120	40.00

# Pipe Schedule

Wall Thickness / Weight (lbs.) per Ft.

Pipe Size	Sched. 5	Sched. 10	Sched. 20	Sched. 30	Sched. 40	STD.	Sched. 60	Sched. 80	Sched. XH	Sched. 100	Sched. 120	Sched. 140	Sched. 160	Sched. XXH
1/8	0.405	.035/1383	.049/1863		.068/2447	.089/2447		.096/3145	.096/3145					
1/4	0.540	.049/2570	.065/3297		.088/4248	.088/4248		.119/5351	.119/5351					
3/8	0.675	.049/3276	.065/4235		.091/5676	.091/5676		.126/7388	.126/7388					
1/2	0.840	.065/5363	.083/671		.109/851	.109/8510		.147/1098	.147/1098					.187/1304
3/4	1.050	.065/6938	.083/8572		.113/1131	.113/1131		.154/1474	.154/1474					.218/1937
1	1.315	.065/9678	.109/1404		.133/1679	.133/1679		.179/2172	.179/2172					.250/2844
1 1/4	1.660	.065/1107	.109/1806		.140/2273	.140/2273		.191/2997	.191/2997					.283/3785
1 1/2	1.900	.065/1274	.109/2095		.145/2718	.145/2718		.200/3631	.200/3631					.291/4959
2	2.375	.065/1604	.109/2638		.164/3653	.164/3653		.218/5022	.218/5022					.343/7444
2 1/2	2.875	.083/2475	.120/3531		.203/5793	.203/5793		.276/7661	.276/7661					.375/10071
3	3.500	.083/3029	.120/4332		.216/7756	.216/7756		.300/1025	.300/1025					.437/1432
3 1/2	4	.083/3472	.120/4973		.226/9109	.226/9109		.318/1251	.318/1251					.638/2285
4	4.500	.083/3945	.120/5613		.237/1079	.237/1079		.281/1266	.317/1498					.674/2754
4 1/2	5				.247/1253	.247/1253		.336/1761	.336/1761					.710/3253
5	5.563	.109/6349	.134/777		.258/1462	.258/1462		.375/2078	.375/2078					.625/3296
6	6.625	.109/7585	.134/9289		.280/1897	.280/1897		.432/2857	.432/2857					.864/5516
7	7.625				.301/2357	.301/2357		.500/3805	.500/3805					.875/6508
8	8.625	.109/9144	.148/134		.322/2855	.322/2855		.500/4339	.500/4339					.875/7242
9	9.625				.342/3390	.342/3390		.500/4872	.500/4872					
10	10.750	.134/519	.165/1870		.365/4048	.365/4048		.500/5474	.500/5474					
11	11.750				.375/4655	.375/4655		.500/6007	.500/6007					
12	12.750	.165/2218	.180/2420		.390/4377	.390/4377		.587/8851	.587/8851					
14	14				.406/5353	.406/5353		.687/8851	.687/8851					
16	16				.437/6337	.437/6337		.750/1061	.750/1061					
18	18				.459/7029	.459/7029		.843/1365	.843/1365					
20	20				.500/8277	.500/8277		.937/1708	.937/1708					
22	22				.550/9462	.550/9462		.1031/2089	.1031/2089					
24	24				.587/1064	.587/1064		.1128/2508	.1128/2508					
26	26				.625/1186	.625/1186		.1218/2984	.1218/2984					
28	28				.662/1308	.662/1308		.1318/3460	.1318/3460					
30	30				.700/1430	.700/1430		.1418/3936	.1418/3936					
32	32				.737/1552	.737/1552		.1518/4412	.1518/4412					
34	34				.775/1674	.775/1674		.1618/4888	.1618/4888					
36	36				.812/1796	.812/1796		.1718/5364	.1718/5364					
42	42				.908/2216	.908/2216		.1918/6240	.1918/6240					
48	48				.1018/7416	.1018/7416		.2118/7116	.2118/7116					

# Pipe Lift Schedule

## 21' Lengths

Nominal Size	Pieces per Lift
1/8	440
1/4	240
3/8	180
1/2	120
3/4	84
1	60
1 1/4	42
1 1/2	36
2	26
2 1/2	18
3	14
3 1/2	11
4	10
5	8
6	7
8	5

## Heavy Expanded Grating



Style	Weight (lbs.) Per Sq. Ft.	Opening Size		Open Area %	Strand Size		Overall Thickness
		SWO	LWO		Width	Thickness	
3.0 lb.	3.00	0.940	3.44	60	0.264	0.183	0.540
3.14 lb.	3.14	1.625	4.88	69	0.312	0.250	0.656
4.0 lb.	4.00	0.940	3.44	55	0.300	0.215	0.618
4.27 lb.	4.27	1.000	2.88	58	0.300	0.250	0.625
5.0 lb.	5.00	0.813	3.38	50	0.331	0.250	0.655
6.25 lb.	6.25	0.813	3.38	50	0.350	0.312	0.715
7.0 lb.	7.00	0.813	3.38	45	0.391	0.312	0.740

## Concrete Reinforcing Bar



Bar Size (Metric)	Weight (lbs.) Per Ft.	Diameter (inches)	Cross Sectional Area- Sq. Inches	Perimeter (inches)
#3(10)	0.376	3/8	0.11	1.178
4 (13)	0.669	1/2	0.20	1.571
5 (16)	1.044	5/8	0.31	1.963
6 (19)	1.503	3/4	0.44	2.356
7 (22)	2.046	7/8	0.60	2.749
8 (25)	2.673	1	0.79	3.142
9 (29)	3.403	1 1/8	1.00	3.544
10 (32)	4.307	1 1/4	1.27	3.990
11 (36)	5.318	1 3/8	1.56	4.430
14 (43)	7.650	1 5/8	2.25	5.320
18 (57)	13.600	2 1/4	4.00	7.090

## Wire Mesh



Style	Gauge	Sheet Size		Sq. Ft. Per Panel	Weight (lbs.) Per Sheet	Weight (lbs.) Per Sq. Ft.
		Width	Length			
6 x 6 W1.4 / W1.4	10	7'6"	x 20'	150	31.5	0.21
6 x 6 W2.1 / W2.1	8	7'6"	x 20'	150	45	0.30
6 x 6 W2.9 / W2.9	6	7'6"	x 20'	150	63	0.42
6 x 6 W4.0 / W4.0	4	7'6"	x 20'	150	87	0.58
4 x 4 W2.9 / W2.9	6	7'0"	x 20'	140	86.8	0.62
4 x 4 W4.0 / W4.0	4	7'0"	x 20'	140	119	0.85

## Steel Weight Calculator

### Bars

Rounds	$\text{Diameter (In.)} \times \text{Diameter (In.)} \times \text{Length (Ft.)} \times 2.6725 = \text{Lbs./ Ea.}$
Squares	$\text{Side (In.)} \times \text{Side (In.)} \times \text{Length (Ft.)} \times 3.4028 = \text{Lbs./Ea.}$
Flats	$\text{Width (In.)} \times \text{Thickness (In.)} \times \text{Length (Ft.)} \times 3.4028 = \text{Lbs./Ea.}$
Hexagons	$\text{Size (In.)} \times \text{Size (In.)} \times \text{Length (Ft.)} \times 2.9469 = \text{Lbs./Ea.}$
Angles	$\text{Leg 1 (In.)} + \text{Leg 2 (In.)} - \text{Thickness (In.)} \times \text{Thickness (In.)} \times \text{Length (Ft.)} \times 3.4028 = \text{Lbs./Ea.}$

### Plates and Sheets

Rectangles and Squares	$\text{Length (In.)} \times \text{Width (In.)} \times \text{Thickness (In.)} \times .2836 = \text{Lbs./Ea.}$
Circles	$\text{Diameter (In.)} \times \text{Diameter (In.)} \times \text{Thickness (In.)} \times .2227 = \text{Lbs./Ea.}$
Triangles	$\text{Base (In.)} \times \text{Height (In.)} \times \text{Thickness (In.)} \times .1418 = \text{Lbs./Ea.}$
Trapezoids (Two sides parallel)	$\text{Side A (In.)} + \text{Side B (In.)} \times \text{Distance C (In.)} \times \text{Thickness (In.)} \times .1418 = \text{Lbs./Ea.}$

### Round Tubing

$(\text{OD} - \text{Wall}) \times \text{Wall} \times 10.68 \times \text{Length (Ft.)} = \text{Lbs./Ea.}$

## Conversion Chart

	When You Know	You Can Find	Multiply By
<b>Length</b>	Inches	Millimeters	25.4
	Feet	Centimeters	30.48
	Yards	Meters	0.9144
	Miles	Kilometers	1.6093
	Millimeters	Inches	0.0394
	Centimeters	Inches	0.3937
	Meters	Yards	1.094
	Kilometers	Miles	0.6214
<b>Area</b>	Sq. Inches	Sq. Centimeters	6.452
	Sq. Feet	Sq. Meters	0.0929
	Sq. Yards	Sq. Meters	0.8361
	Sq. Miles	Sq. Kilometers	2.59
	Acres	Sq. Hectometers	0.4047
	Sq. Centimeters	Sq. Inches	0.155
	Sq. Meters	Sq. Yards	1.196
	Sq. Kilometers	Sq. Miles	0.3861
	Sq. Hectometers	Acres	2.471
<b>Mass</b>	Ounces	Grams	28.349
	Pounds	Kilograms	0.4536
	Short Tons	Megagrams (Metric Tons)	0.9072
	Grams	Ounces	0.0353
	Kilograms	Pounds	2.2046
	Megagrams (Metric Tons)	Short Tons	1.1023
<b>Liquid Volume</b>	Ounces	Milliliters	29.57
	Pints	Liters	0.4732
	Quarts	Liters	0.9463
	Gallons	Liters	3.785
	Milliliters	Ounces	0.0338
	Liters	Pints	2.113
	Liters	Quarts	1.057
	Liters	Gallons	0.2642
<b>Temperature</b>	Fahrenheit	Celsius	Subtract 32, then multiply by 5/9.
	Celsius	Fahrenheit	Multiply by 9/5, then add 32.

## Useful Information

To find circumference of a circle, multiply diameter by 3.1416.

To find diameter of a circle, multiply circumference by .31831.

To find area of a circle, multiply of diameter by .7854.

Area of a rectangle = length multiplied by breadth. Doubling the diameter of a circle increases its area four times.

To find area of a triangle, multiply base by 1/2 perpendicular height.

Area of ellipse = product of both diameters x .7854.

Area of parallelogram = base x altitude.

To find side of an inscribed square, multiply diameter by .7071 or multiply circumference by .2251 or divide circumference by 4.4428.

Side of inscribed cube = radius of sphere x 1.1547.

To find side of an equal square, multiply diameter by .8862.

Square. A side multiplied by 1.4142 equals diameter of its circumscribing circle.

A side multiplied by 4.443 equals circumference of its circumscribing circle.

A side multiplied by 1.128 equals diameter of an equal circle.

A side multiplied by 3.547 equals circumference of an equal circle.

To find cubic inches in a ball, multiply cube of diameter by .5236.

To find cubic contents of a cone, multiply area of base by 1/3 the altitude.

Doubling the diameter of a pipe increases its capacity four times.

A gallon of water (U.S. standard) weighs 8-1/3 pounds and contains 231 cubic inches.

A cubic foot of water contains 7-1/2 gallons, 1728 cubic inches and weighs 62-1/2 pounds.

To find the pressure in pounds per square inch of a column of water, multiply the height of the column in feet by .434.

Steam rising from water at its boiling point (212 degrees F.) has a pressure equal to the atmosphere (14.7 pounds to the square inch).

A standard horsepower: the evaporation of 30 lbs. Of water per hour from a feed water temperature of 100 degrees F. into steam at 70 lbs. Gauge pressure.

To find capacity of tanks any size, given dimensions of a cylinder in inches, to find its capacity in U.S. gallons: square the diameter, multiply by the length and by .0034.



## Converting Inches Into Decimals of a Foot

Inches	Decimal of a Foot	Inches	Decimal of a Foot	Inches	Decimal of a Foot
		1	0.0833	2	1/6
1/16	0.0052	1 1/16	0.0885	2 1/16	0.1719
1/8	0.0104	1 1/8	0.0938	2 1/8	0.1771
7/8	0.0156	1 7/8	0.099	2 3/16	0.1823
1/4	0.0208	1 1/4	0.1042	2 1/4	0.1875
5/16	0.0260	1 5/16	0.1094	2 5/16	0.1927
3/8	0.0313	1 3/8	0.1146	2 3/8	0.1979
7/16	0.0365	1 7/16	0.1198	2 7/16	0.2031
1/2	0.0417	1 1/2	0.125	2 1/2	0.2083
9/16	0.0469	1 9/16	0.1302	2 9/16	0.2135
5/8	0.0521	1 5/8	0.1354	2 5/8	0.2188
11/16	0.0573	1 11/16	0.1406	2 11/16	0.2240
3/4	0.0625	1 3/4	0.1458	2 3/4	0.2292
13/16	0.0677	1 13/16	0.151	2 13/16	0.2344
7/8	0.0729	1 7/8	0.1563	2 7/8	0.2396
15/16	0.0781	1 15/16	0.1615	2 15/16	0.2448

Inches	Decimal of a Foot	Inches	Decimal of a Foot	Inches	Decimal of a Foot
3	0.2500	4	0.3333	5	0.4167
3 1/16	0.2552	4 1/16	0.3385	5 1/16	0.4219
3 1/8	0.2604	4 1/8	0.3438	5 1/8	0.4271
3 3/16	0.2656	4 3/16	0.3490	5 3/16	0.4323
3 1/4	0.2708	4 1/4	0.3542	5 1/4	0.4375
3 5/16	0.2760	4 5/16	0.3594	5 5/16	0.4427
3 3/8	0.2813	4 3/8	0.3646	5 3/8	0.4479
3 7/16	0.2865	4 7/16	0.3698	5 7/16	0.4531
3 1/2	0.2917	4 1/2	0.3750	5 1/2	0.4583
3 9/16	0.2969	4 9/16	0.3802	5 9/16	0.4635
3 5/8	0.3021	4 5/8	0.3854	5 5/8	0.4688
3 11/16	0.3073	4 11/16	0.3906	5 11/16	0.4740
3 3/4	0.3125	4 3/4	0.3968	5 3/4	0.4792
3 13/16	0.3177	4 13/16	0.4010	5 13/16	0.4844
3 7/8	0.3229	4 7/8	0.4063	5 7/8	0.4896
3 15/16	0.3281	4 15/16	0.4115	5 15/16	0.4948

Inches	Decimal of a Foot	Inches	Decimal of a Foot	Inches	Decimal of a Foot
6	0.5000	7	0.5833	8	0.6667
6 1/16	0.5052	7 1/16	0.5885	8 1/16	0.6719
6 1/8	0.5104	7 1/8	0.5938	8 1/8	0.6771
6 3/16	0.5156	7 3/16	0.5990	8 3/16	0.6823
6 1/4	0.5208	7 1/4	0.6042	8 1/4	0.6875
6 5/16	0.5260	7 5/16	0.6094	8 5/16	0.6927
6 3/8	0.5313	7 3/8	0.6146	8 3/8	0.6979
6 7/16	0.5365	7 7/16	0.6198	8 7/16	0.7031
6 1/2	0.5417	7 1/2	0.6250	8 1/2	0.7083
6 9/16	0.5469	7 9/16	0.6302	8 9/16	0.7135
6 5/8	0.5521	7 5/8	0.6354	8 5/8	0.7188

6 11/16	0.5573	7 11/16	0.6406	8 11/16	0.7240
6 3/4	0.5625	7 3/4	0.6458	8 3/4	0.7292
6 13/16	0.5677	7 13/16	0.6510	8 13/16	0.7344
6 7/8	0.5729	7 7/8	0.6563	8 7/8	0.7396
6 15/16	0.5781	7 15/16	0.6615	8 15/16	0.7448

<u>Inches</u>	<u>Decimal of a Foot</u>	<u>Inches</u>	<u>Decimal of a Foot</u>	<u>Inches</u>	<u>Decimal of a Foot</u>
9	0.7500	10	0.8333	11	0.9167
9 1/16	0.7552	10 1/16	0.8385	11 1/16	0.9219
9 1/8	0.7604	10 1/8	0.8438	11 1/8	0.9271
9 3/16	0.7656	10 3/16	0.8490	11 3/16	0.9323
9 1/4	0.7708	10 1/4	0.8542	11 1/4	0.9375
9 5/16	0.7760	10 5/16	0.8594	11 5/16	0.9427
9 3/8	0.7813	10 3/8	0.8646	11 3/8	0.9479
9 7/16	0.7865	10 7/16	0.8698	11 7/16	0.9531
9 1/2	0.7917	10 1/2	0.8750	11 1/2	0.9583
9 9/16	0.7969	10 9/16	0.8802	11 9/16	0.9635
9 5/8	0.8021	10 5/8	0.8854	11 5/8	0.9688
9 11/16	0.8073	10 11/16	0.8906	11 11/16	0.9740
9 3/4	0.8125	10 3/4	0.8958	11 3/4	0.9792
9 13/16	0.8177	10 13/16	0.9010	11 13/16	0.9844
9 7/8	0.8229	10 7/8	0.9063	11 7/8	0.9896
9 15/16	0.8281	10 15/16	0.9115	11 15/16	0.9948

Bar Size		Nominal Weight		Nominal Dimensions	
		lb. / ft.	( kg / m )	inches	( millimeters )
imperial	metric				
#3	[ # 10 ]	0.376	(.560)	0.375	(9.5)
#4	[ # 13 ]	0.668	(.994)	0.500	(12.7)
#5	[ # 16 ]	1.043	(1.552)	0.625	(15.9)
#6	[ # 19 ]	1.502	(2.235)	0.750	(19.1)
#7	[ # 22 ]	2.044	(3.042)	0.875	(22.2)
#8	[ # 25 ]	2.670	(3.974)	1.000	(25.4)
#9	[ # 29 ]	3.400	(5.060)	1.128	(28.7)
#10	[ # 32 ]	4.303	(6.404)	1.270	(32.3)
#11	[ # 36 ]	5.313	(7.907)	1.410	(35.8)
#14	[ # 43 ]	7.650	(11.390)	1.693	(43.0)
#18	[ # 57 ]	13.600	(20.240)	2.257	(57.3)

135° Seismic Stirrup / Tie  
Hook dimensions  
( min. ACI 318 requirements )

Bar Size	D in. [mm]	135° Hooks	
		Hook A or G in. [mm]	H (approx.)
#3 [#10]	1 1/2 [40]	4 1/4 [110]	3 [80]
#4 [#13]	2 [50]	4 1/2 [115]	3 [80]
#5 [#16]	2 1/2 [65]	5 1/2 [140]	3 3/4 [95]
#6 [#19]	4 1/2 [115]	8 [205]	4 1/2 [115]
#7 [#22]	5 1/4 [135]	9 [230]	5 1/4 [135]
#8 [#25]	6 [155]	10 1/2 [270]	6 [155]

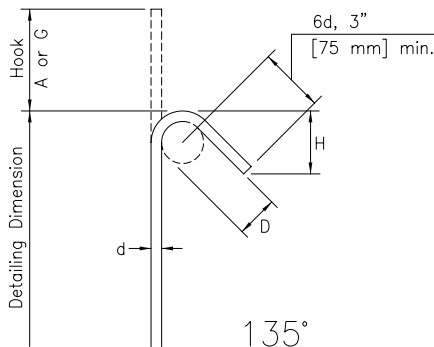

D = Finished bend diameter

# Recommended End Hooks

( min. ACI 318 requirements )

Bar Size	D in. [mm]	180° Hooks		90° Hooks
		A or G ft.-in. [mm]	J ft.-in. [mm]	A or G ft.-in. [mm]
#3 [#10]	2 1/4 [60]	0-5 [125]	0-3 [80]	0-6 [150]
#4 [#13]	3 [80]	0-6 [150]	0-4 [105]	0-8 [200]
#5 [#16]	3 3/4 [95]	0-7 [175]	0-5 [130]	0-10 [250]
#6 [#19]	4 1/2 [115]	0-8 [200]	0-6 [155]	1-0 [300]
#7 [#22]	5 1/4 [135]	0-10 [250]	0-7 [180]	1-2 [375]
#8 [#25]	6 [155]	0-11 [275]	0-8 [205]	1-4 [425]
#9 [#29]	9 1/2 [240]	1-3 [375]	11 3/4 [300]	1-7 [475]
#10 [#32]	10 3/4 [275]	1-5 [425]	1-1 1/4 [335]	1-10 [550]
#11 [#36]	12 [305]	1-7 [475]	1-2 3/4 [375]	2-0 [600]
#14 [#43]	18 1/4 [465]	2-3 [675]	1-9 3/4 [550]	2-7 [775]
#18 [#57]	24 [610]	3-0 [925]	2-4 1/2 [725]	3-5 [1050]

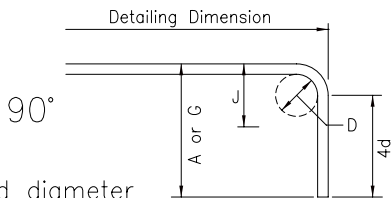
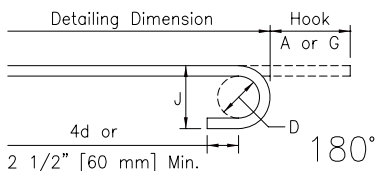

D = Finished bend diameter

# Stirrup ( Ties Similar )

Stirrup and tie hook dimensions  
( min. ACI 318 requirements )

Bar Size	D in. [mm]	90° Hooks	135° Hooks	
		A or G ft.-in. [mm]	Hook A or G in. [mm]	H (approx.)
#3 [#10]	1 1/2 [40]	0-4 [105]	4 [105]	2 1/2 [65]
#4 [#13]	2 [50]	0-4 1/2 [115]	0-4 1/2 [115]	3 [80]
#5 [#16]	2 1/2 [65]	0-6 [155]	5 1/2 [140]	3 3/4 [95]
#6 [#19]	4 1/2 [115]	1-0 [305]	8 [205]	4 1/2 [115]
#7 [#22]	5 1/4 [135]	1-2 [355]	9 [230]	5 1/4 [135]
#8 [#25]	6 [155]	1-4 [410]	10 1/2 [270]	6 [155]

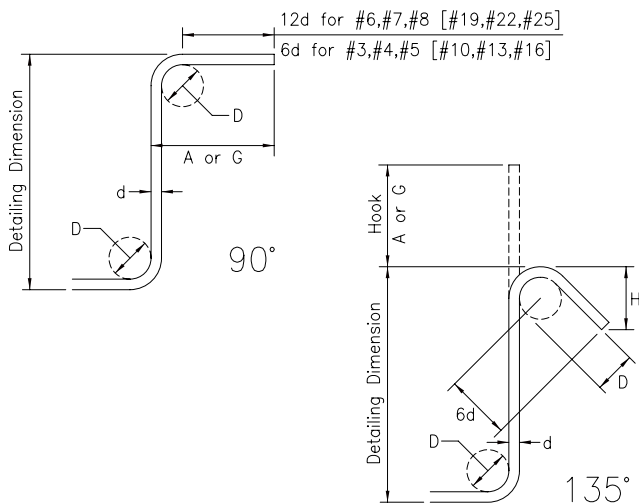

D = Finished bend diameter

# TELEPHONE ORDER SELECTION FOR FORMING PLATE

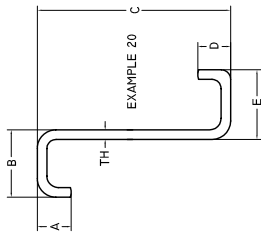
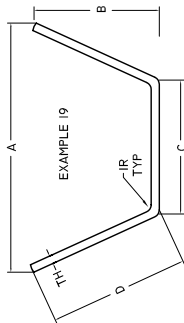
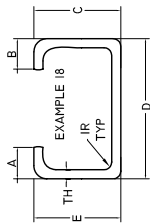
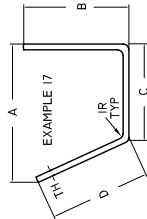
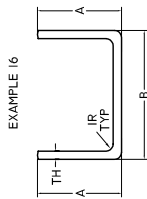
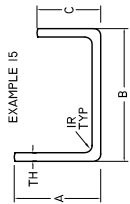
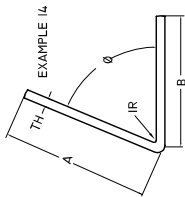
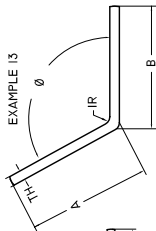
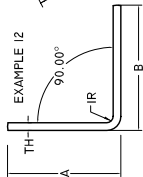

# TELEPHONE ORDER SELECTION FOR FORMING PLATE

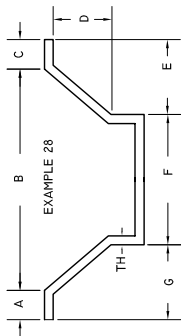
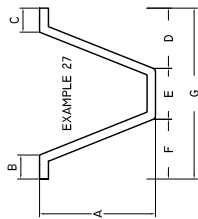
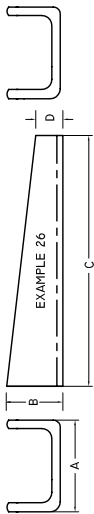
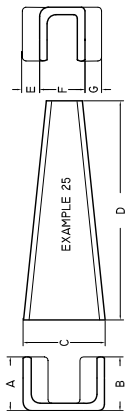
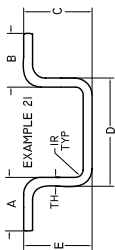
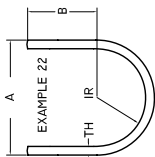
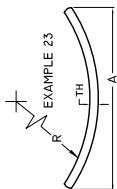
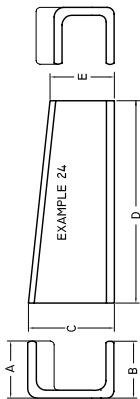



## ORDER SELECTION FOR MITER CUTTING ANGLE

- MAXIMUM SIZE IS 12" SQUARE
- MAXIMUM MITER CAPABILITY IS 45° (A1 & A2)
- CUTTING TOLERANCE +/- 1/8"

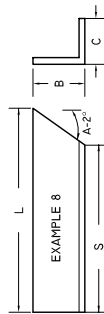
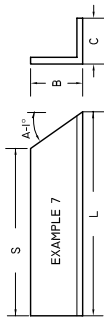
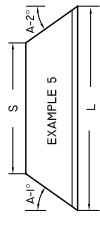
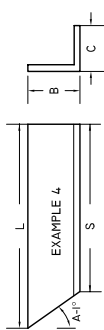
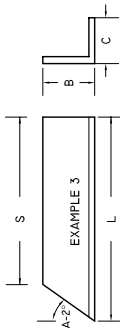
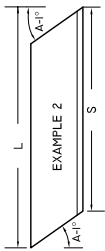
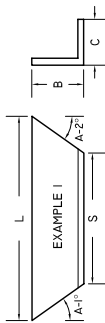

## ORDER SELECTION FOR MITER CUTTING BEAMS

- MAXIMUM SIZE IS 12" SQUARE
- MAXIMUM MITER CAPABILITY IS 45° (A1 & A2)
- CUTTING TOLERANCE +/- 1/8"

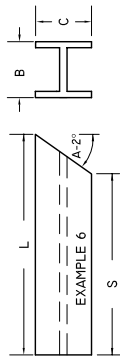
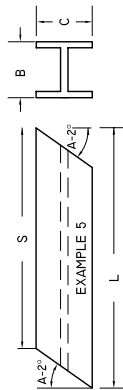
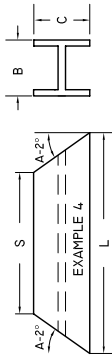
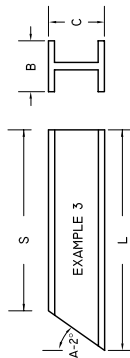
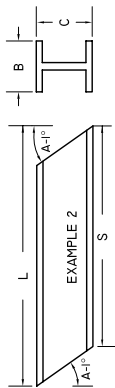
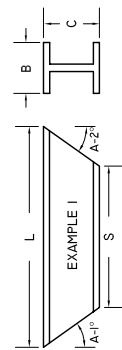

## ORDER SELECTION FOR MITER CUTTING CHANNEL

- MAXIMUM SIZE IS 12" SQUARE
- MAXIMUM MITER CAPABILITY IS 45° (A1 & A2)
- CUTTING TOLERANCE +/- 1/8"

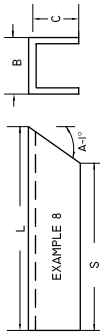
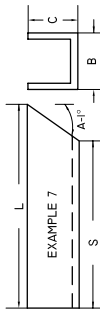
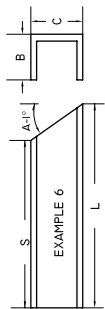
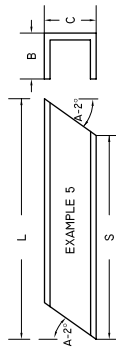
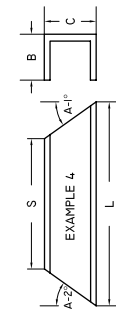
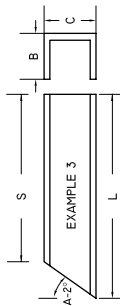
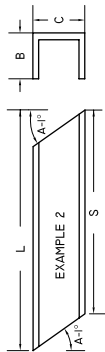
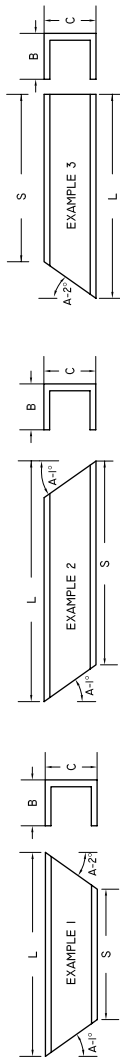

## ORDER SELECTION FOR MITER CUTTING TUBE

- MAXIMUM SIZE IS 12" SQUARE
- MAXIMUM MITER CAPABILITY IS 45° (A1 & A2)
- CUTTING TOLERANCE +/- 1/8"

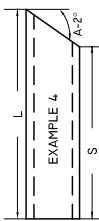
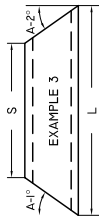

# TELEPHONE ORDER SELECTION FOR PLATE PATTERN CUTTING

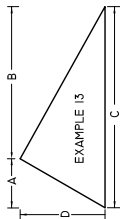
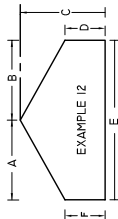
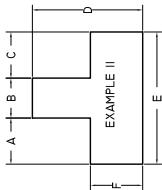
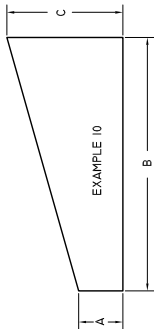
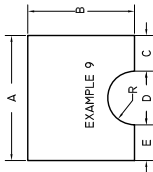
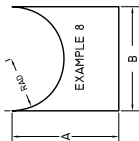
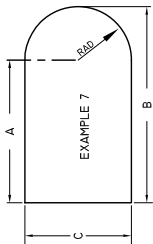
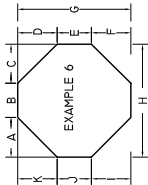
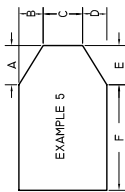
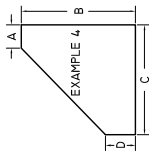
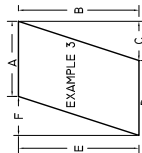
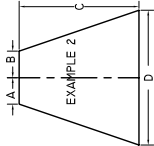
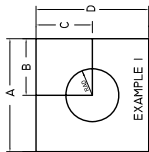

TELEPHONE ORDER SELECTION  
FOR PLATE PATTERN CUTTING

